

HidROS

ENERGY RECOVERY HIGH EFFICIENCY DEHUMIDIFIERS

UTA

SERIES



R410A

 E.C.

TECHNICAL MANUAL

Incorporated in this document are the following:

- Declaration of conformity
- Technical manual
- Dimensional drawing
- Wiring diagrams



ISO 9001 - Cert. n. 5205/0

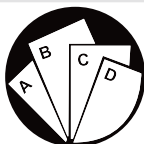

Multiple instructions:
Consult the specific part



Read and understand
the instructions before
undertaking any work on
the unit

RETAIN FOR FUTURE REFERENCE

Reproduction, data storage and transmission, even partial, of this publication, in any form, without the prior written authorisation of HIDROS S.p.A., is prohibited. HIDROS S.p.A. can be contacted for all inquiries regarding the use of its products.

HIDROS S.p.A. follows a policy of continuous product development and improvement and reserves the right to modify specifications, equipment and instructions regarding use and maintenance at any time, without notice.

Declaration of conformity

We declare under our own responsibility that the below equipment complies in all parts with the CEE and EN directives.

The declaration of conformity is enclosed to the technical booklet enclosed with the unit.

INDEX

1. INTRODUCTION	5
1.1 Preliminary information	5
1.2 Aim and content of the manual	5
1.3 How to store this manual	5
1.4 Manual Update	5
1.5 How to use this manual	5
1.6 Potential Risks	6
1.7 General Description of Symbols Used	7
1.8 Safety symbols used	8
1.9 Limitations and prohibited use	9
1.10 Unit identification	9
2. SAFETY	10
2.1 Warning re potentially hazardous toxic substances	10
2.2 Refrigerant handling	10
2.3 Prevent inhalation of high vapor concentration	11
2.4 Procedures to be adopted in the event of accidental release of refrigerant	11
2.5 Main Toxicological Information Regarding the Type of refrigerant used	11
2.6 First Aid Measures	11
3. TECHNICAL CHARACTERISTICS	12
3.1 Unit description	12
3.2 Other versions	13
3.3 Accessories description	14
3.4 Operation principle	14
3.5 Technical data	15
3.6 Partial heat recovery (accessory)	17
3.7 Hot water coil (accessory)	18
3.8 Fans	19
3.9 Low ambient temperature device (DBRC)	21
3.10 Operation limits	22
3.11 Sound data	23
3.12 Safety devices	23
3.13 Electrical data	23
4. INSTALLATION	24
4.1 General safety guidelines and use of symbols	24
4.2. Health and safety Considerations	24
4.3 Personal protective equipment	24
4.4 Inspection	25
4.5 Storage	25
4.6 Unpacking	25
4.7 Lifting and handling	26
4.8 Location and minimum technical clearances	26
4.9 Condensate draining connections	27
4.10 Ductwork unit connection	27
4.11 Installation of built-in room electronic sensor (RGDD)	29
4.12 How to remove filters	29
4.13 Partial heat recovery hydraulic connections (option)	30
4.14 Hot water coil hydraulic connections	31
4.15 Refrigerant connections for z version	31
4.16 Refrigerant diameters lines for version UTAZ	32
4.17 Electric connections: preliminary safety information	33
4.18 Electrical data	34
4.19 How to connect the power supply	34
4.20 Electric connections	35
4.21 Fans	36
5. UNIT START UP	36

5.1 Preliminary checks.....	36
5.2 Description of the control panel	37
5.3 Description of the remote control panel.....	37
6. USE	39
6.1 Unit On/Off.....	39
6.2 Main menù	40
6.3 User menu	41
6.4 Maintenance menu	43
6.5 Alarm history menu	51
6.6 Clock Menu	52
6.7 Input/Output Menu	52
6.8 Info Menu.....	54
7. MAINTENANCE OF THE UNIT	54
7.1 General warnings.....	54
7.2 Drive access	54
7.3 Periodical checks.....	55
7.4 Refrigerant circuit repair	55
7. DECOMMISSIONING.....	56
7.1 Disconnect the unit	56
7.2 Disposal, recovery and recycling.....	56
7.3 RAEE Directive (only UE).....	56
8. DIAGNOSIS AND TROUBLESHOOTING	57
8.1 Fault finding	57
9.DIMENSIONAL DRAWINGS	58

1. INTRODUCTION

1.1 Preliminary information

Reproduction, storage or transmission of any part of this publication in any form, without the prior written consent of the Company, is prohibited.

The unit to which these instructions refer, is designed to be used for the the purposes described and to be operated in accordance with these instructions.

The Company will not be liable for claims for damage caused to persons, animals, material goods or property caused by improper installation, adjustment and maintenance or improper use. Any use not specified in this manual is prohibited.

This document is intended to provide information only and does not form a contract with third parties.

The Company pursues a policy of constant improvement and development of its products and therefore reserves the right to change the specifications and the documentation at any time, without notice and without obligation to update existing equipment.

1.2 Aim and content of the manual

These instructions are intended to provide the information required for the selection, installation, use and maintenance of the unit.

They have been prepared in accordance with the European Union laws and with the technical standards in force at the date of issue of the instructions.

The instructions contain all the necessary information to prevent any reasonably foreseeable misuse.

1.3 How to store this manual

The manual must be kept in a suitable place with easy access for users and operators, protected from dust and damp.

The manual must always accompany the unit during the entire life cycle of the same and therefore must be transferred to any subsequent user.

1.4 Manual Update

It is recommended that the manual is updated to the latest revision available.

If updates are sent to the customer they must be added to this manual.

The latest information regarding the use of its products is available by contacting the Company.

1.5 How to use this manual



The manual is an integral part of the unit.

Users or operators must consult the manual before performing any operation and especially so when transporting, handling, installing, maintaining, or dismantling the unit in order to eliminate uncertainty and reduce risk.



In these instructions symbols have been used (described in the following paragraphs) to draw the attention of operators and users to the operations that have a higher risk and which must be performed safely.

1.6 Potential Risks

Whilst the unit has been designed to minimize any risk posed to the safety of people who will interact with it, it has not been technically possible to eliminate completely the causes of risk. It is therefore necessary to refer to the requirements and symbolism below:

LOCATION OF RISK	POTENTIAL RISK	METHOD OF INJURY	PRECAUTIONS
Thermal heat exchangers.	Small stab wounds.	Contact	Avoid any contact, use protective gloves.
Fan and fan grilles.	Cuts, eye damage, broken bones.	Insertion of sharp objects through the grid while the fans are operating.	Never put objects through the protection grilles.
Internal component: compressors and discharge pipes	Burns.	Contact	Avoid any contact, use protective gloves.
Internal component: electric cables and metallic parts	Electrocution, severe burns.	Defect in the supply cable insulation, live metallic parts.	Adequate protection of power cables, ensure correct earthing of all metal parts.
External to unit: unit enclosure	Poisoning, severe burns.	Fire due to short circuit or overheating of the supply cable external to unit.	Size cables and mains protection system in accordance with iee regulations.
Low pressure safety valve.	Poisoning, severe burns.	High evaporating pressure causing a refrigerant discharge during maintenance.	Carefully check the evaporating pressure during the maintenance operations.
High pressure safety valve.	Poisoning, severe burns, hearing loss.	Activation of the high pressure safety valve with the refrigerant circuit open.	If possible, do not open the refrigerant circuit valve; carefully check the condensing pressure; use all the personal protective equipment required by law.
Entire unit	External fire	Fire due to natural disasters or combustions of elements nearby unit	Provide the necessary fire-fighting equipment

1.7 General Description of Symbols Used

Safety symbols combined in accordance with ISO 3864-2:



BANNED

A black symbol inside a red circle with a red diagonal indicates an action that should not be performed.



WARNING

A black graphic symbol added to a yellow triangle with black edges indicates danger.



ACTION REQUIRED

A white symbol inserted in a blue circle indicates an action that must be done to avoid a risk.

Safety symbols combined in accordance with ISO 3864-2:



The graphic symbol “warning” is qualified with additional safety information (text or other symbols).

1.8 Safety symbols used



GENERAL RISK

Observe all signs placed next to the pictogram. The failure to follow directions may create a risk situation that may be injurious to the user.



ELECTRICAL HAZARD

Observe all signs placed next to the pictogram.

The symbol indicates components of the unit and actions described in this manual that could create an electrical hazard.



MOVING PARTS

The symbol indicates those moving parts of the unit that could create risk.



HOT SURFACES

The symbol indicates those components with high surface temperature that could create risks.



SHARP SURFACES

The symbol indicates components or parts that could cause stab wounds.



EARTH CONNECTION

The symbol identifies Earthing connection points in the unit.



READ AND UNDERSTAND THE INSTRUCTIONS

Read and understand the instructions of the machine before any operations.



RECOVER OR RECYCLE MATERIAL

1.9 Limitations and prohibited use

The machine is designed and built exclusively for the uses described in “Limitations of use” of the technical manual. Any other use is prohibited because it may pose a potential risk to the health of operators and users.



- The unit is not suitable for operations in environments:
- excessively dusty or potentially explosive atmospheres;
 - where there are vibrations;
 - where there are electromagnetic fields;
 - where there are aggressive atmospheres

1.10 Unit identification

Each unit has a rating plate that provides key information regarding the machine. The rating plate may differ from the one shown below as the example is for a standard unit without accessories. For all electrical information not provided on the label, refer to the wiring diagram. A facsimile of the label is shown below:

		Via E. Mattei, 20 35028 Piove di Sacco PD Italy	
Manufacturer: PD322111			
Contiene gas fluorurati ad effetto serra disciplinati dal protocollo di Kyoto Contains fluorinated greenhouse gasses covered by the Kyoto protocol			
Deumidificatore/Dehumidifier Luftenfeuchter/Dèshumidificateur	1UTA.015A-1C	Matricola/Serial number Matrikel/Matricule	210151
Tensione-Fasi-Frequenza Voltage-Phases-Frequency Spannung-Phasen-Frequenz Tension-Phases-Fréquence	400v-3PH+N-50Hz	Corrente massima assorbita Max absorbed current Maximalstromverbrauch Courant maxi absorbée	8,6 A
Tipo refrigerante Refrigerant type Kältemittel typ Type de refrigerant	R410A	Carica refrigerante Refrigerant charge Kältemittelfüllung Charge de refrigerant	2,30 kg
Max press. di esercizio (alta/bassa) Max allowable press. (high/low) Max kältermit betriebsdruck (hoch/nieder) Press. maxi admissible (haut/bas)	30/19 bar	Data di produzione Manufacturing date Erstellungsdatum Date de fabrication	10/2014



The product label should never be removed from the unit.

2. SAFETY

2.1 Warning re potentially hazardous toxic substances

2.1.1 Identification of the Type of Refrigerant Fluid Used: R410A

- Difluoromethane (HFC-32) 50% by weight CAS No.: 000075-10-5
- Pentafluoroethane (HFC-125) 50% by weight CAS No.: 000354-33-6

2.1.2 Identification of the Type of Oil Used.

The lubricant used is polyester oil. Please refer to the information provided on the compressor data plate.



For further information regarding the characteristics of the refrigerant and oil used, refer to the safety data sheets available from the refrigerant and oil manufacturers.

Main Ecological Information Regarding the Types of refrigerants Fluids used.



ENVIRONMENTAL PROTECTION : Read the ecological information and the following instructions carefully.

2.1.3 Persistence and degradation

The refrigerants used decompose in the lower atmosphere (troposphere) relatively quickly. The decomposed products are highly dispersible and therefore have a very low concentration. They do not influence the photochemical smog which is not among the VOC volatile organic compounds (as stipulated in the guidelines to the UNECE). The constituent refrigerants of R407C (R32, R125 and R134a), do not damage the ozone layer. These substances are regulated under the Montreal Protocol (revised 1992) and regulations EC no. 2037/2000 of 29 June 2000.

2.1.4 Effects of discharges

Discharges into the atmosphere of this product does not cause a long-term contamination.

2.1.5 Exposure controls and personal protection

Wear protective clothing and gloves, protect your eyes and face

2.1.6 Professional exposure limits

R410A
 HFC-32 TWA 1000 ppm
 HFC-125 TWA 1000 ppm

2.2 Refrigerant handling



Users and maintenance personnel must be adequately informed about the possible risks of handling potentially toxic substances. Failure to follow such instructions can cause damage to personnel or to the unit.

2.3 Prevent inhalation of high vapor concentration

Atmospheric concentrations of refrigerant must be minimized and kept to a level that is below the occupational exposure limit. Vapor is heavier than air and can form dangerous concentrations near the ground where the ventilation rate is lower. Always ensure adequate ventilation. Avoid contact with open flames and hot surfaces as this can cause toxic and irritating decomposition products to form. Avoid contact between liquid refrigerant and the eyes or skin.

2.4 Procedures to be adopted in the event of accidental release of refrigerant

Ensure suitable personal protection (especially respiratory protection) during cleaning operations.

If deemed safe, isolate the source of the leak. If the leakage is small and if adequate ventilation is provided, allow the refrigerant to evaporate. If the loss is substantial ensure that measures are taken to adequately ventilate the area.

Contain spilled material with sand, earth or other suitable absorbent material.

Do not allow the refrigerant to enter drains, sewers or basements, as pockets of vapor can form.

2.5 Main Toxicological Information Regarding the Type of refrigerant used

2.5.1 Inhalation

A high atmospheric concentration can cause anaesthetic effects with possible loss of consciousness. Prolonged exposure may lead to irregular heartbeat and cause sudden death. Higher concentrations may cause asphyxia due to the reduced oxygen content in the atmosphere.

2.5.2 Contact with skin

Splashes of nebulous liquid can produce frostbite. Probably not hazardous if absorbed through the skin. Repeated or prolonged contact may remove the skin's natural oils, with consequent dryness, cracking and dermatitis.

2.5.3 Contact with eyes

Splashes of liquid may cause frostbite.

2.5.4 Ingestion

While highly improbable, may produce frostbite.

2.6 First Aid Measures



Adhere scrupulously to the warnings and first aid procedures indicated below.

2.6.1 Inhalation

Move the person away from the source of exposure, keep him/her warm and let him/her rest. Administer oxygen if necessary. Attempt artificial respiration if breathing has stopped or shows signs of stopping. If the heart stops, perform external heart massage. Seek medical assistance.

2.6.2 Contact with skin

In case of contact with skin, wash immediately with lukewarm water. Thaw tissue using water. Remove contaminated clothing. Clothing may stick to the skin in case of frostbite. If irritation, swelling or blisters appear, seek medical assistance.

2.6.3 Contact with eyes

Rinse immediately using an eyewash or clean water, keeping eyelids open, for at least ten minutes. Seek medical assistance.

2.6.4 Ingestion

Do not induce vomiting. If the injured person is conscious, rinse his/her mouth with water and make him/her drink 200-300ml of water. Seek immediate medical assistance.

2.6.5 Further medical treatment

Treat symptoms and carry out support therapy as indicated. Do not administer adrenaline or similar sympathomimetic drugs following exposure, due to the risk of cardiac arrhythmia.

3. TECHNICAL CHARACTERISTICS

3.1 Unit description

The energy recovery high efficiency dehumidifiers UTA range have been designed to grant the complete control of temperature, humidity, the energy recovery and the fresh air treatment in the covered swimming pools or in other applications with very high internal loads. The UTA units can operate in environments up to 36°C and are able to manage up to 30% of fresh air. The range includes 7 models, which covers airflows range from 1500 to 6000 m³/h. The use of double-passage-cross-flow energy recovery allows to increase up to 30% the dehumidification capacity in comparison to the traditional dehumidifiers. The use of the double passage in the energy recovery, in fact, allows the free sensible pre-cooling of the air near to the saturation point, giving so the possibility to the unit to work, basically, in latent load.

3.1.1 Frame

All UTA units are made from hot-galvanised thick sheet metal, painted with polyurethane powder enamel at 180°C to ensure the best resistance against the atmospheric agents and to operate in aggressive environments. The frame is self-supporting with removable panels. A stainless steel drip tray is installed on all units. The colour of the units is RAL 7035.

3.1.2 Refrigerant circuit

The refrigerant circuit is made by using international primary brands components and according to ISO 97/23 concerning welding procedures. The refrigerant gas used in these units is R410A. The refrigerant circuit includes: sight glass, filter drier, thermal expansion valve with external equalizer, liquid line manual shut-off valve, Schrader valves for maintenance and control, pressure safety device (according to PED regulation).

3.1.3 Compressor

The compressor is scroll type, with crankcase heater and thermal overload protection by a klixon embedded in the motor winding. The compressor is mounted on rubber vibration dampers and, upon request, can be supplied with sound-proof cover to reduce noise emission (accessory). The crankcase heater, when present, is always powered when the compressor is in stand-by. The inspection is possible through the frontal panel of the unit that allows the maintenance of the compressor.

3.1.4 Condenser and evaporator

Condensers and evaporators are made of copper pipes and aluminium fins. All coils are painted with epoxy powders to prevent corrosion problem due to their use in aggressive environments. The diameter of the copper pipes is 3/8" and the thickness of the aluminium fins is 0,1 mm. The tubes are mechanically expanded into the aluminium fins to improve the heat exchange factor. The geometry of these condensers guarantees a low air side pressure drop and then the use of low rotation (and low noise emission) fans. All units are supplied, standard, with a stainless steel drip tray and all evaporators are supplied with a temperature sensor used as automatic defrost probe.

3.1.5 Heat recovery

The heat recovery is cross flow heat exchanger type, with painted aluminium plates; painted galvanised steel frame with additional tightening of the heat exchange pack, in order to operate in aggressive environments; it has a low pressure drop value and it is always supplied with stainless steel drip tray.

3.1.6 Hot water coil

The hot water coil is made of copper pipes and aluminium fins. The diameter of the copper pipes is 3/8" and the thickness of the aluminium fins is 0,1 mm. The tubes are mechanically expanded into the aluminium fins to improve the heat exchange factor. All coils are supplied with a built-in 3 way modulating valve, directly managed by the microprocessor of the unit.

3.1.7 E.C. supply fan

The supply fan is a high performance centrifugal type, double inlet forward curved blades, directly coupled to the electric motor. The fan wheel and the scroll are made from hot galvanised thick sheet metal, painted with polyurethane powders, to ensure the best resistance against aggressive environments. The electric motor is a high efficiency DC brushless type with external rotor, to guarantee an ideal cooling of the windings and the absence of power lost due to pulleys and belt transmission. The fan is statically and dynamically balanced class 6,3 according to ISO1940. The electric motor has a separate electronic commutator (driver) and a speed modulation 0-10V, integrated PFC, burn out thermal protection (in case of considerable reduction of the power supply), protection degree IP54, serial interface card with modbus protocol RTU.

3.1.8 E.C. exhaust fan

The exhaust fan is a high performance centrifugal type, double inlet forward curved blades, directly coupled to the electric motor. The fan wheel and the scroll are made from hot galvanised thick sheet metal, painted with polyurethane powders, to ensure the best resistance against aggressive environments. The electric motor is a high efficiency DC brushless type with external rotor, to guarantee an ideal cooling

of the windings and the absence of power lost due to pulleys and belt transmission. The fan is statically and dynamically balanced class 6,3 according to ISO1940. The electric motor has a separate electronic commutator (driver) and a speed modulation 0-10V, integrated PFC, burn out thermal protection (in case of considerable reduction of the power supply), protection degree IP54, serial interface card with modbus protocol RTU.

3.1.9 Exhaust and fresh air dampers

The exhaust and fresh air dampers are made of aluminium frame and fins, distance between the fins 150 mm. The bushes are in nylon; exhaust and fresh air dampers are connected each other and supplied already with servomotor managed by the microprocessor of the unit.

3.1.10 Air filter

It's supplied standard with the unit. It's made of filtering material in synthetic fibre without electrostatic charge. It can be removed for differential disposal, class G5, according to EN 779:2002.

3.1.11 Microprocessor

All UTA units are supplied standard with microprocessor controls. The microprocessor controls the following functions: compressor timing, automatic defrost cycles, the management of fresh and exhaust air, post heating valve and alarms. An appropriate LCD display shows the operation mode of the unit, set point and alarms.

3.1.12 Electric box

The electric switch board is made according to electromagnetic compatibility norms CEE 73/23 and 89/336. The accessibility to the board is possible after removing the front panel of the unit and the OFF positioning of the main switch. In all UTA units are installed, standard, the compressors sequence relay which disables the operation of the compressor in case the power supply phase sequence is not the correct one (scroll compressors in fact, can be damaged if they rotate reverse wise). The following components are also standard installed: main switch, magnetic-thermal switches (as a protection of pumps and fans), compressors fuses, control circuit automatic breakers, compressor contactors, fan contactors, pump contactors. The terminal board is also supplied with voltage free contacts for remote ON-OFF.

3.1.13 Control and protection devices

All units are supplied with the following control and protection devices: defrost thermostat, which signals to the microprocessor control that a defrost cycle is needed and controls its termination, high pressure switch with manual reset, low pressure switch with automatic reset, high pressure safety valve, compressor thermal overload protection, fans thermal overload protection.

3.1.14 Test

All the units are fully assembled and wired at the factory, carefully evacuated and dried after leak tests under pressure and then charged with refrigerant R410A. They are all fully operational tested before shipment. They all conform to European Directives and are individually marked with the CE label and provided with Conformity Declaration.

3.2 Other versions

3.2.1 Version with temperature control (UTAZ)

These versions are supplied with a remote condenser and are used in those applications where it is necessary the simultaneous control of temperature and humidity: Dehumidification mode: the internal condenser is activated; the unit dehumidifies and heats up the room temperature; Cooling mode: the remote condenser is activated; the unit dehumidifies and cools down the room temperature.

3.3 Accessories description

3.3.1 Remote control panel (PCRL)

The remote control panel replicates all of the functions on the main controller panel and can be connected up to a maximum distance of 50 meters from the unit. The panel has to be connected to the unit by telephone cable.

3.3.2 Low ambient temperature device with heat recovery (DBRC)

The low ambient temperature device is used when the fresh air temperature is lower than -5°C and allows the correct operation of the unit with very low ambient temperatures (down to -30°C).

The device is made of a heat recovery composed by 2 water+ glycol coils connected with a water pump. The upper coil recovers the thermal load of the exhaust air, the mixture (glycol +water) in the coil is warmed up, then it is moved to the lower coil where the thermal load is transferred to the fresh air that is pre-heat before entering in the unit.

3.3.3 Partial heat recovery Cu-Ni made (RP01)

The unit is fitted with a Coaxial type heat exchanger suitable for chlorinated water. The internal pipe is manufactured from Cupronickel with the external pipe being made from Copper. The chlorinated water flows within the internal pipe whilst the refrigerant gas passes through the gap between the internal and external pipes. The Cupronickel internal pipe is manufactured with a special profile that generates turbulent flow within the refrigerant gas thus increasing the heat exchange factor, the thermal efficiency and reducing the dimensions. The heat exchanger is designed to recover approx. 20% of the thermal capacity generated by the unit.

3.4 Operation principle

The hot and humid return airflow, moved by the fan (G), passes in the return filter (A), then across the first side of the energy recovery (B) where, crossing the cold air present on the other side, leaves part of its enthalpy. At this point part of the treated air (from 0% to 30%) is removed by the exhaust fan (C), while the remaining part passes across the cold evaporating coil (D) where it is dried at the required level. After the evaporator the cold and dried airflow is mixed with fresh air (from 0% to 30%) entered through the fresh air damper (E) and returned into the energy recovery for the second passage where, crossing the hot air present on the other side, it is warmed up. The airflow then passes across the condensing coil (F) where it is post heated and finally sent into the swimming pool. In case the air discharge temperature is still too cold, the hot water temperature coil H (accessory) will provide to increase it up to the required level.

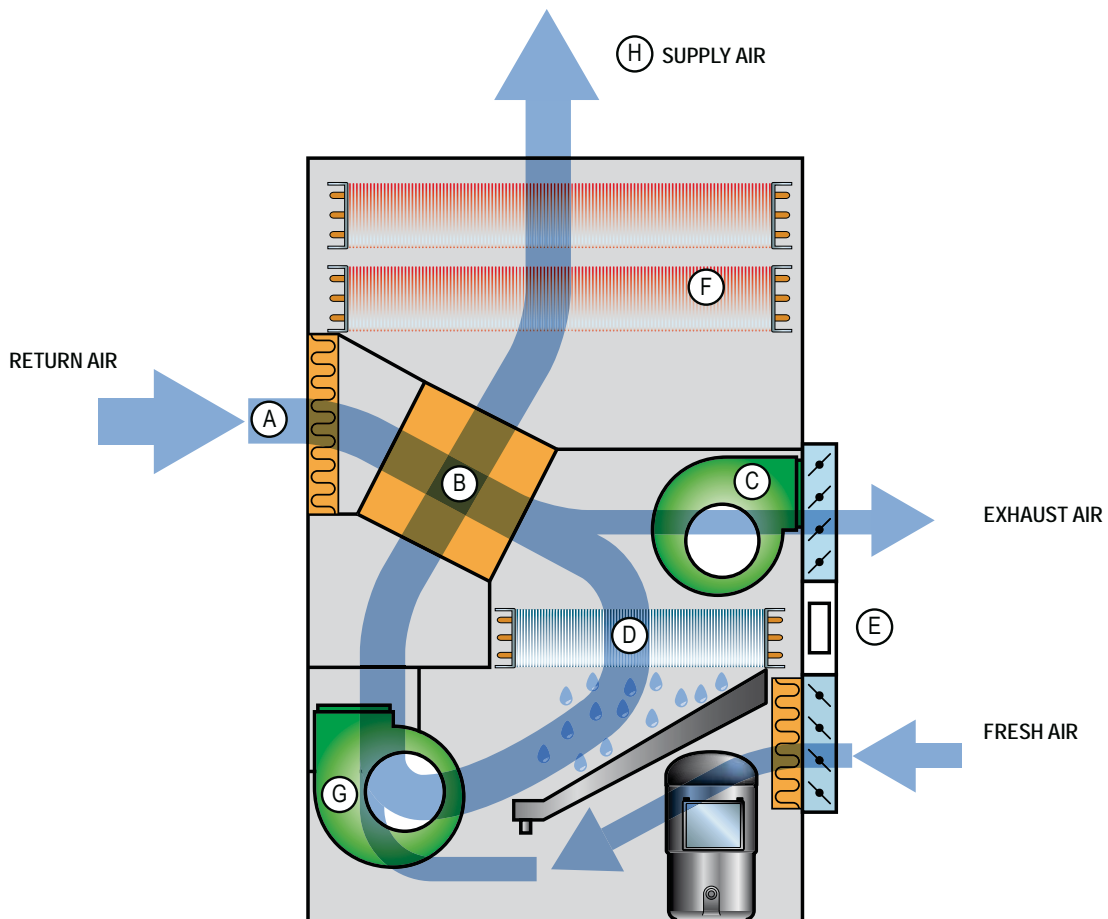

3.5 Technical data

3.5.1 Technical data UTA

Models UTA		015	020	028	035	042	052	060
Refrigerant		R410A	R410A	R410A	R410A	R410A	R410A	R410A
Moisture removed ⁽¹⁾	l/24h	132,7	162,3	248,9	310,7	376,0	464,4	565,2
Moisture removed ⁽²⁾	l/24h	223,0	290,9	444,8	552,2	587,5	746,4	907,5
Nominal input power ⁽¹⁾	kW	3,7	4,4	7,4	9,0	11,0	14,0	15,7
Maximum input current	A	17,0	21,0	22,0	24,0	26,0	31,0	33,3
Hot water coil ⁽³⁾	kW	18,0	23,0	28,0	33,0	53,0	64,0	70,0
Total air flow	m ³ /h	1500	2000	2800	3500	4200	5200	6000
Available static pressure	Pa	200	200	200	200	200	200	200
Maximum fresh air flow	m ³ /h	450	600	845	1050	1260	1560	1800
Sound pression ⁽⁴⁾	dB (A)	63	63	66	66	68	69	69
Temperature operating range	°C	10-36	10-36	10-36	10-36	10-36	10-36	10-36
Humidity operating range	%	50-99	50-99	50-99	50-99	50-99	50-99	50-99
Power supply	V/Ph/Hz	400/3+N/50	400/3+N/50	400/3+N/50	400/3+N/50	400/3+N/50	400/3+N/50	400/3+N/50

Performances refer to the following conditions:

- (1) Room temperature 30°C; relative humidity 60%, fresh air 0%.
- (2) Room temperature 30°C; relative humidity 60%, fresh air 30% (5°C-80%).
- (3) Room temperature 30°C; water temperature 80/70°C, unit compressor in stand-by
- (4) Sound pressure level measured at 1 mt from the unit in free field conditions according to ISO 9614.

3.5.2 Technical data UTA / Z

Models UTA		015	020	028	035	042	052	060
Refrigerant		R410A	R410A	R410A	R410A	R410A	R410A	R410A
Moisture removed ⁽¹⁾	l/24h	132,7	162,3	248,9	310,7	376,0	464,4	565,2
Moisture removed ⁽²⁾	l/24h	223,0	290,9	444,8	552,2	587,5	746,4	907,5
Cooling capacity ⁽³⁾	kW	3,5	4,7	6,5	8,3	10,0	12,2	14,0
Nominal input power ⁽¹⁾	kW	4,5	5,0	8,0	9,5	12,0	14,0	16,0
Maximum input current	A	18,5	22,0	23,0	24,0	27,0	33,0	35,0
Hot water coil ⁽⁴⁾	kW	18,0	23,0	28,0	33,0	53,0	64,0	70,0
Total air flow	m ³ /h	1500	2000	2800	3500	4200	5200	6000
Available static pressure	Pa	200	200	200	200	200	200	200
Maximum fresh air flow	m ³ /h	450	600	845	1050	1260	1560	1800
Sound pression ⁽⁵⁾	dB (A)	63	63	66	66	68	69	69
Temperature operating range	°C	10-36	10-36	10-36	10-36	10-36	10-36	10-36
Humidity operating range	%	50-99	50-99	50-99	50-99	50-99	50-99	50-99
Power supply	V/Ph/Hz	400/3+N/50	400/3+N/50	400/3+N/50	400/3+N/50	400/3+N/50	400/3+N/50	400/3+N/50

Performances are referred to the following conditions:

- (1) Room temperature 30°C; relative humidity 60%, fresh air 0%.
- (2) Room temperature 30°C; relative humidity 60%, fresh air 30% (5°C-80%).
- (3) Room temperature 30°C; relative humidity 60%, fresh air 0% (35°C-50%), net sensible cooling capacity in the room.
- (4) Room temperature 30°C; water temperature 80/70°C, unit compressor in stand-by
- (5) Sound pressure level measured at 1 mt from the unit in free field conditions according to ISO 9614.

3.5.3 Remote condenser technical data

Models UTAZ		015	020	028	035	042	052	060
Refrigerant		R410A	R410A	R410A	R410A	R410A	R410A	R410A
Max input power	kW	0,14	0,14	0,28	0,28	0,28	0,39	0,39
Max input current	A	0,63	0,63	1,26	1,26	1,26	1,70	1,70
Power supply	V/Ph/Hz	230/1/50	230/1/50	230/1/50	230/1/50	230/1/50	230/1/50	230/1/50
Total air flow	m ³ /h	3500	3500	7000	7000	7000	9000	9000
Sound power ⁽¹⁾	dB(A)	62	62	65	65	65	67	67
Sound pression ⁽²⁾	dB(A)	34	34	37	37	37	39	39

Performance refer to the following conditions:

(1) Sound power level according to ISO 9614.

(2) Sound pressure level at 10 mt from the unit in free field conditions direction factor Q=2, in accordance with ISO 9614.

3.5.4 Fresh air treatment

All units can operate with fresh air up to 30% of the total nominal airflow managed by the unit. The fresh air, winter season, has a humidity content that is extremely lower than the indoor air and its use can increase the dehumidification of the unit using the same airflow.

In the below diagram you may note that using fresh air we can supply in the room air with a lower dew point but, obviously, in this case the fresh air will have to be heated before to be supplied in the room with consequent higher thermal load of the heating coil.

- A-B1 Sensible cooling made in the cross flow heat recovery (27-65% / 23-80%)
- B1-D2 Cooling with dehumidification in the evaporator of the unit (23-80% / 17-95%)
- D2-B3 Heating in the cross flow heat recovery (without fresh air) (17-95% / 22-75%)
- B3-F2 Post-heating in the condenser of the unit (without fresh air) (22-75% / 38-28%)
- D2-B2 Mixing with 30% fresh air (17-95% / 13-100%)
- B2-B3 Heating in the cross flow heat recovery (with 30% fresh air) (13-100% / 18,5-70%)
- B3-F2 Post-heating in the condenser of the unit (with 30% fresh air) (18,5-70% / 35-26%)

The specific dehumidification capacity of the UTR, in total air recirculation (internal conditions 27°C, 65% R.H.) is about 2.5 gr/kg of treated air. In case of using 30% fresh air, at 5°C and 80% R.H., the specific dehumidification capacity of the unit will increase of about 3 gr/kg, doubling practically, the specific dehumidification capacity (5,5 gr/kg).

It is clear that, in case of use of fresh air, the air discharge temperature will be lower (35°C instead of 38°C) and will have to be heated before to be supplied in the room.

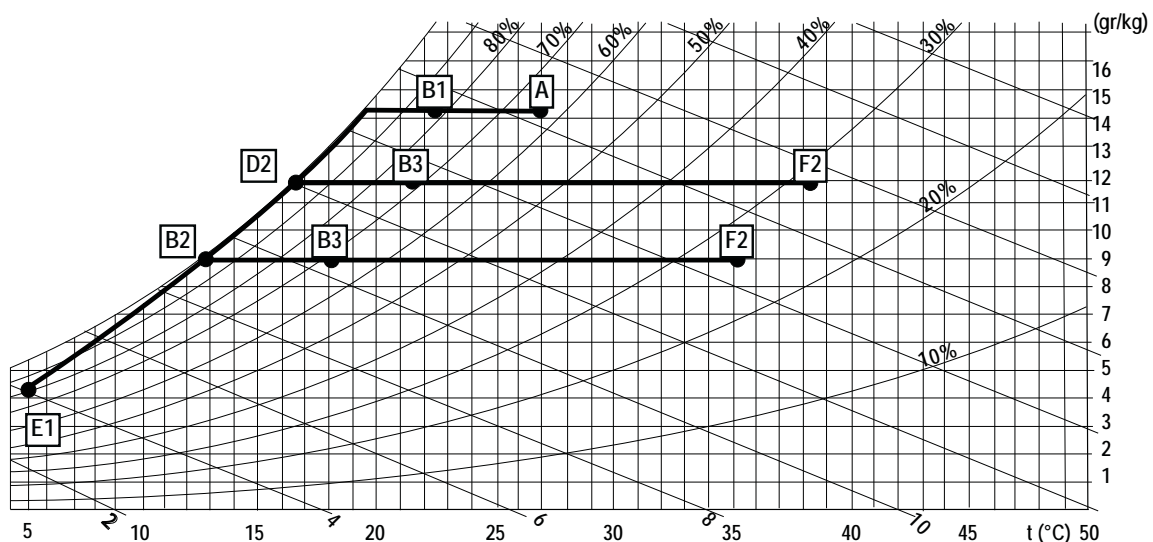

3.6 Partial heat recovery (accessory)

Modelli UTA		015	020	028	035	042	052	060
Nominal heating capacity	kW	1,6	2,2	3,7	4,5	5,8	6,7	8,1
Water flow	l/h	275	380	640	780	1000	1150	1400
Water pressure drops	kPa	11	7	8	11	12	13	13

Nominal data are referred to room temperature 30°C and water outlet temperature 30°C (Dt 5°C).

The heat recovery capacity in different conditions can be obtained multiplying the nominal capacity (See above), by the correction factor indicated in the table.

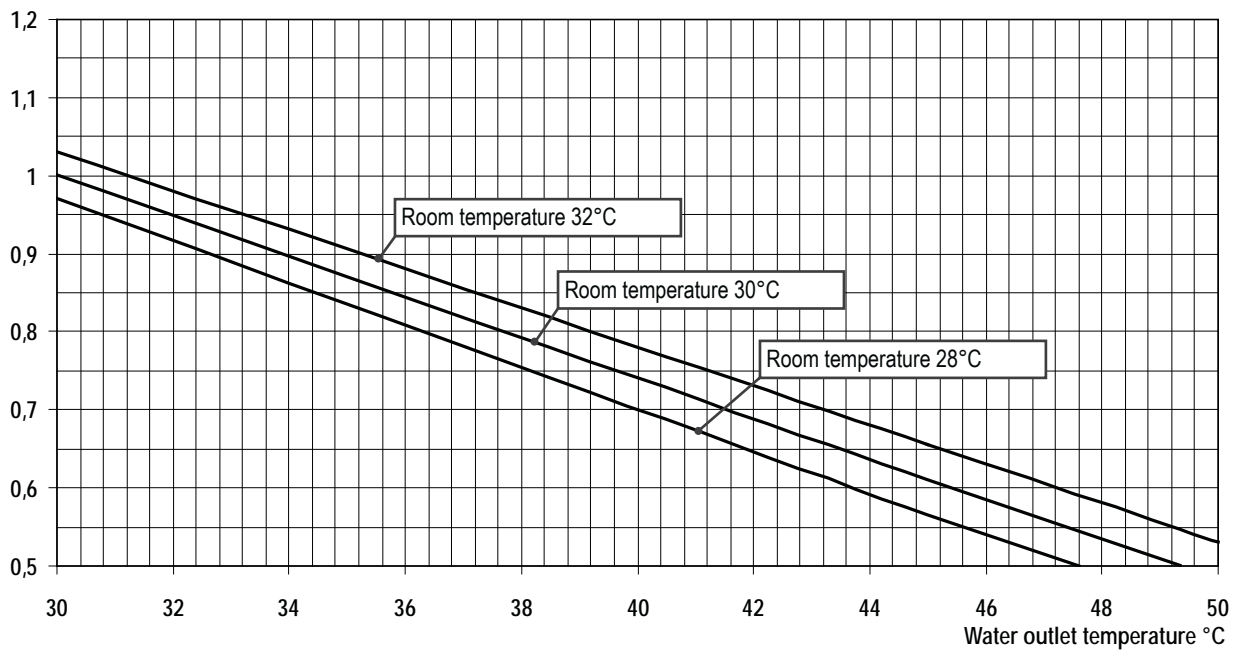

3.6.1 Water pressure drops

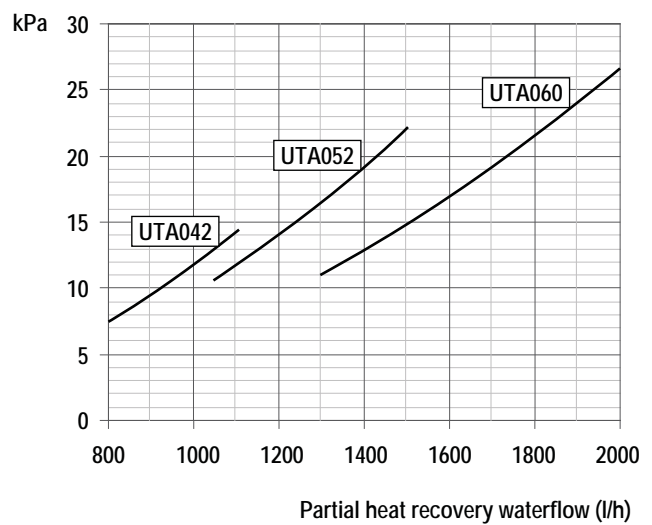
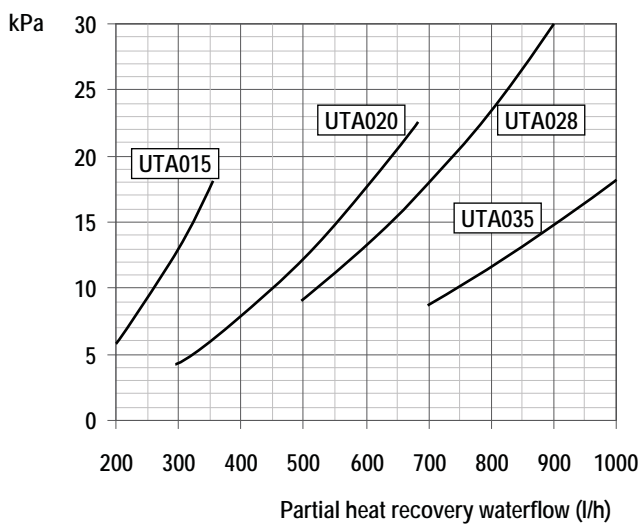

3.7 Hot water coil (accessory)

UTA Models		015	020	028	035	042	052	060
Hot water coil capacity	kW	15	18,3	28,4	33	44	50,8	55,8
Water flow	l/h	1290	1580	2500	2900	3800	4400	4800
Water pressure drops	kPa	11	16	25	33	16	21	25

Nominal data are referred to room temperature 32°C and water temperature 80/70°C .

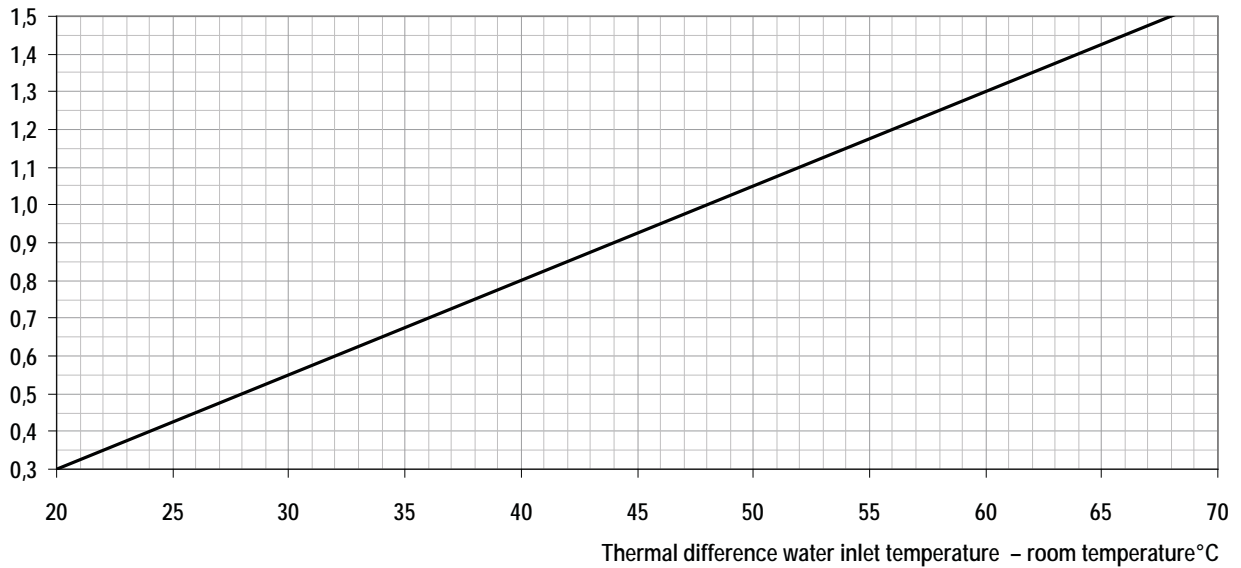

The hot water coil capacity in different conditions can be obtained multiplying the nominal capacity (See above), by the correction factor indicated in the table.

3.7.1 Water pressure drops

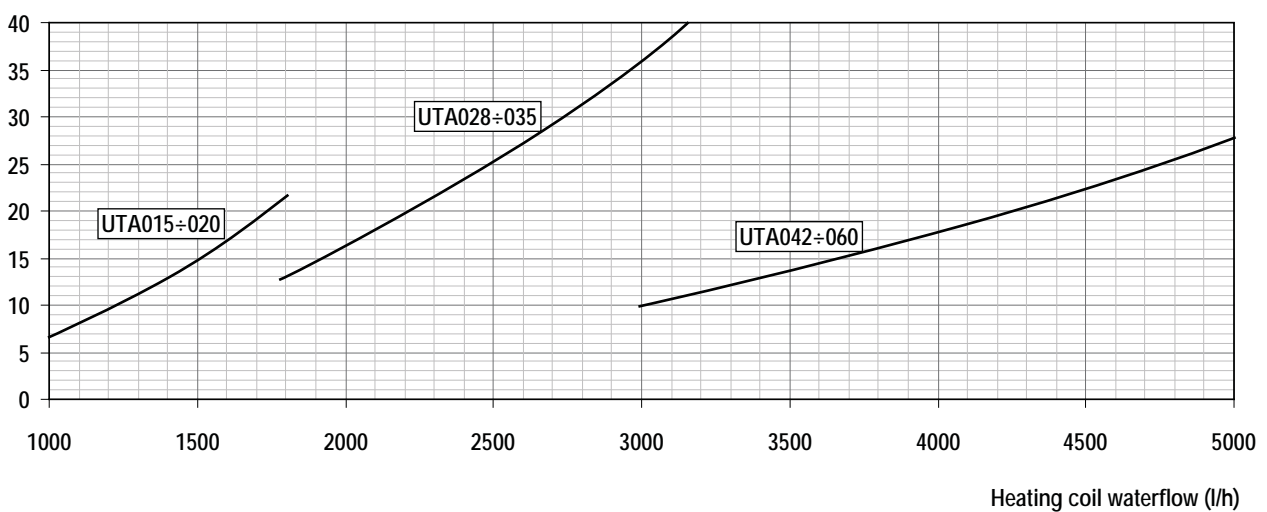

3.7 Fans

Supply fan

UTA 015

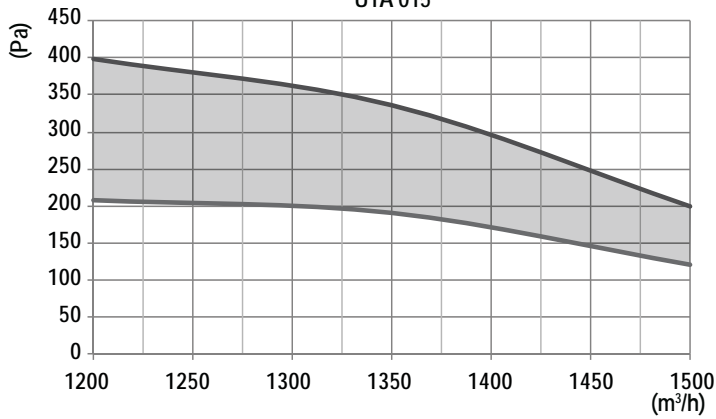

Exhaust fan

UTA 015

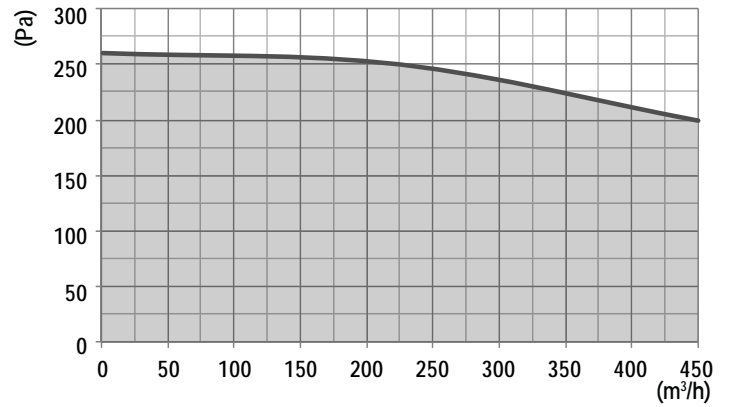

UTA 020

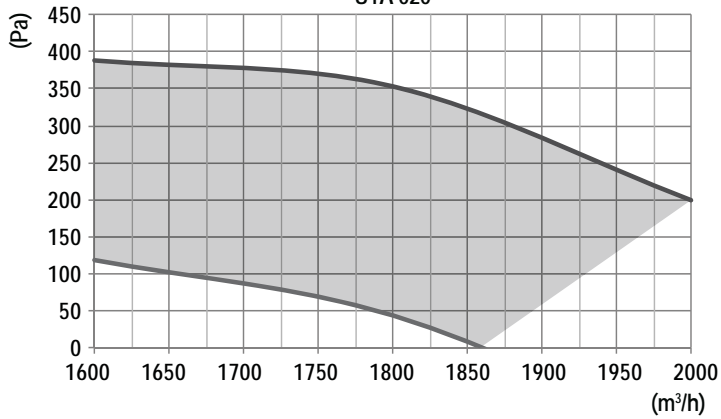

UTA 020

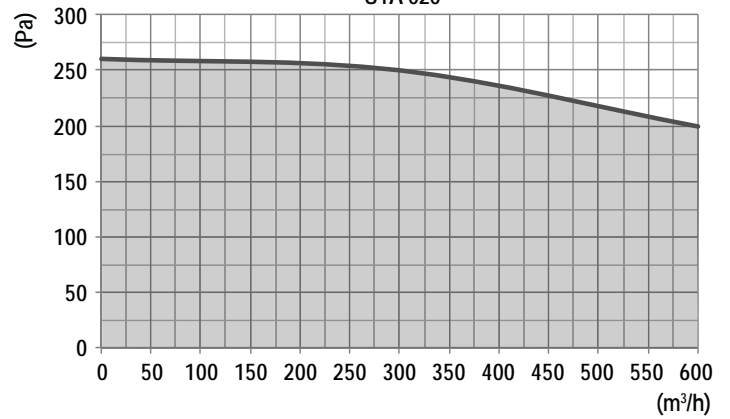

UTA 028

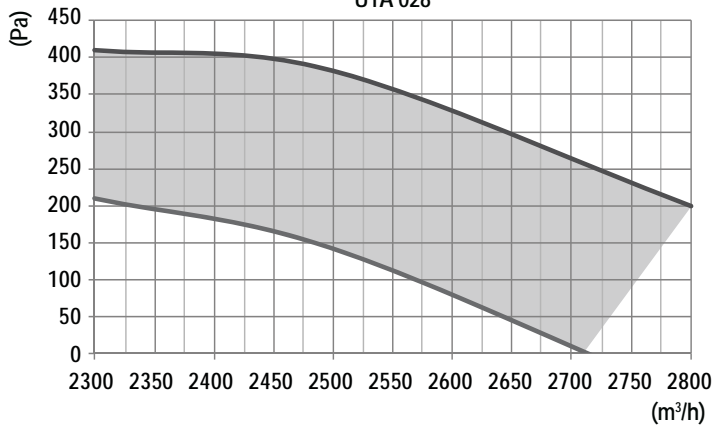

UTA 028

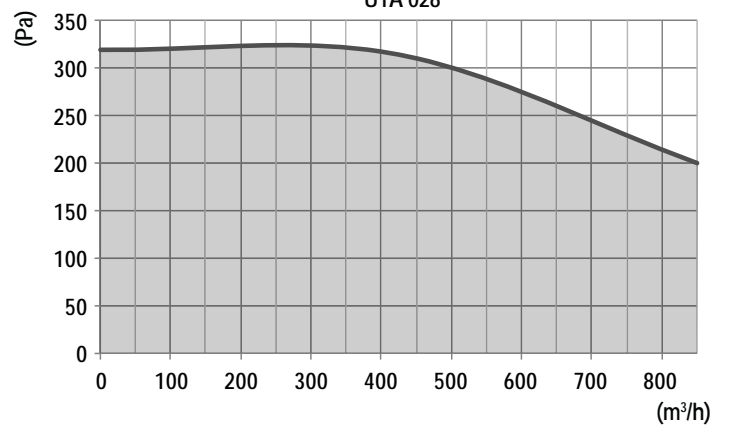

UTA 035

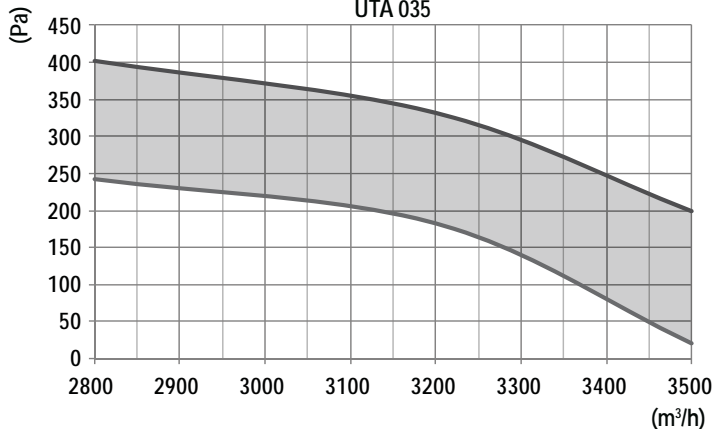

UTA 035

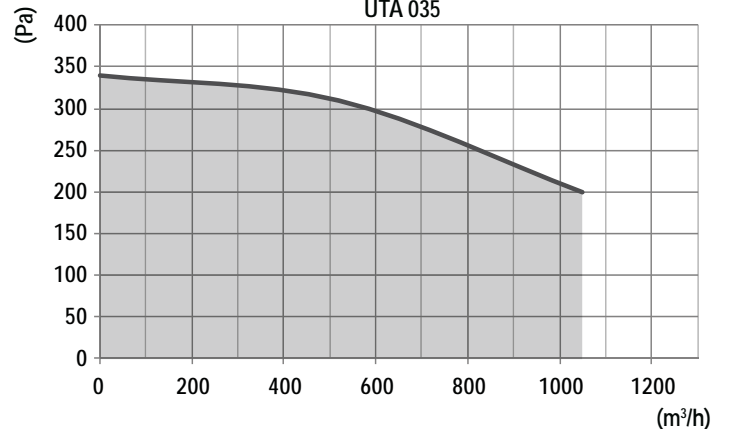

Supply fan

UTA 042

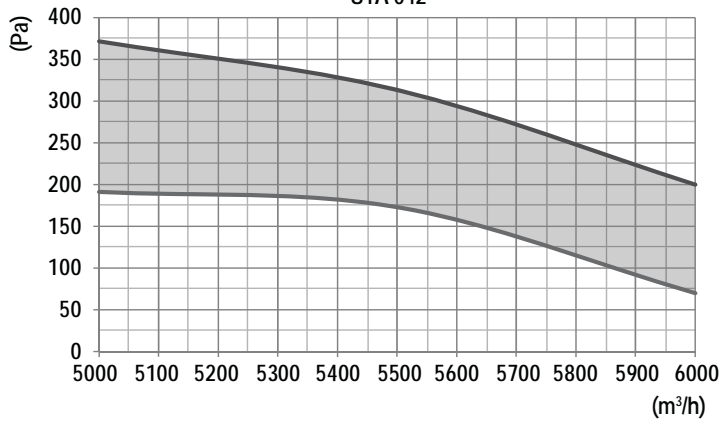

Exhaust fan

UTA 042

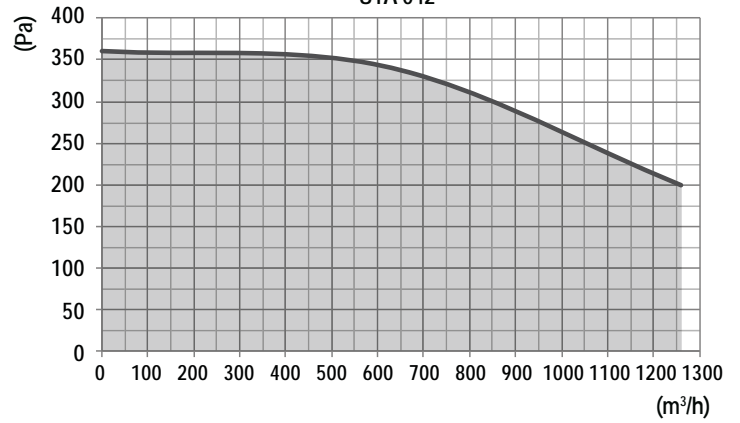

UTA 052

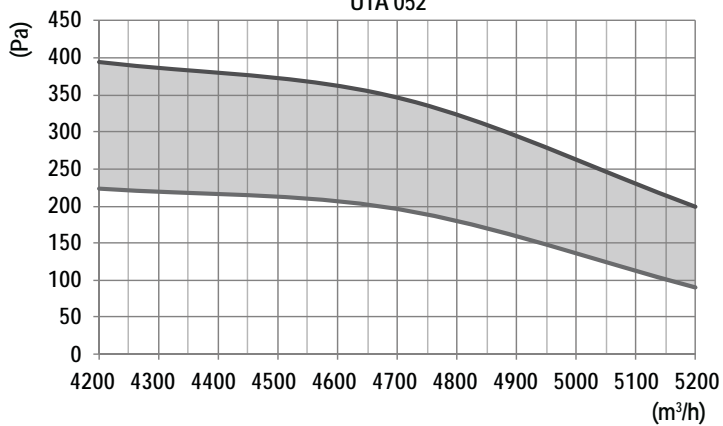

UTA 052

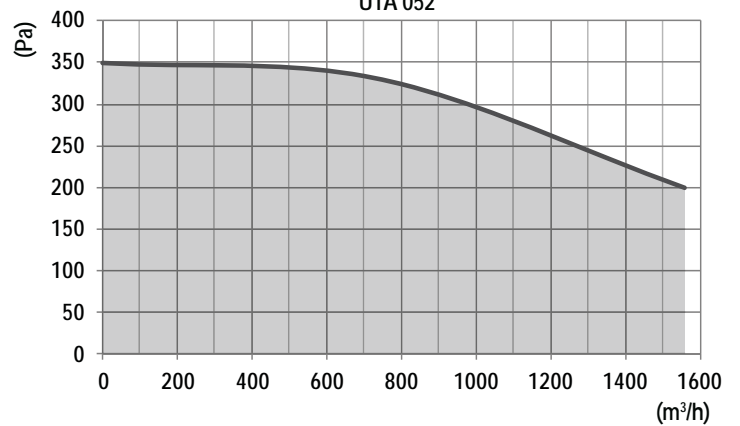

UTA 060

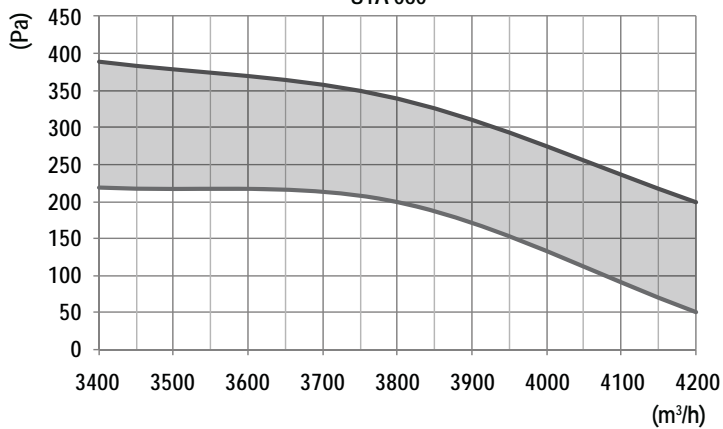

UTA 060

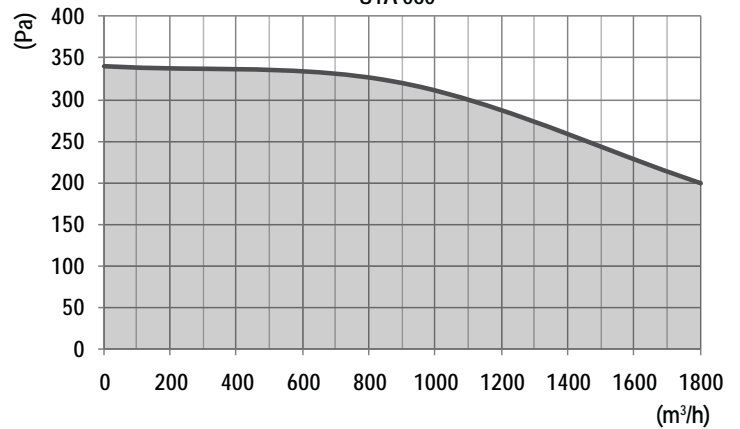

In order to enable the proper functioning of the unit is important to ensure a constant air flow to the unit close to the nominal stated value. The maximum deviation allowed is 10%.

3.8 Low ambient temperature device (DBRC)

The low ambient temperature device is used when the fresh air temperature is lower than -5°C and allows the correct operation of the unit with very low ambient temperatures (down to -30°C).

The device is made of a heat recovery composed by 2 water+ glycol coils connected with a water pump. The upper coil recovers the thermal load of the exhaust air, the mixture (glycol +water) in the coil is warmed up, then it is moved to the lower coil where the thermal load is transferred to the fresh air that is pre-heat before entering in the unit. The use of this device allows two advantages:

- An additional heat recovery on the exhaust air increasing then the unit energy efficiency,
- The fresh air inlet is suitable for the correct operation of the internal components.

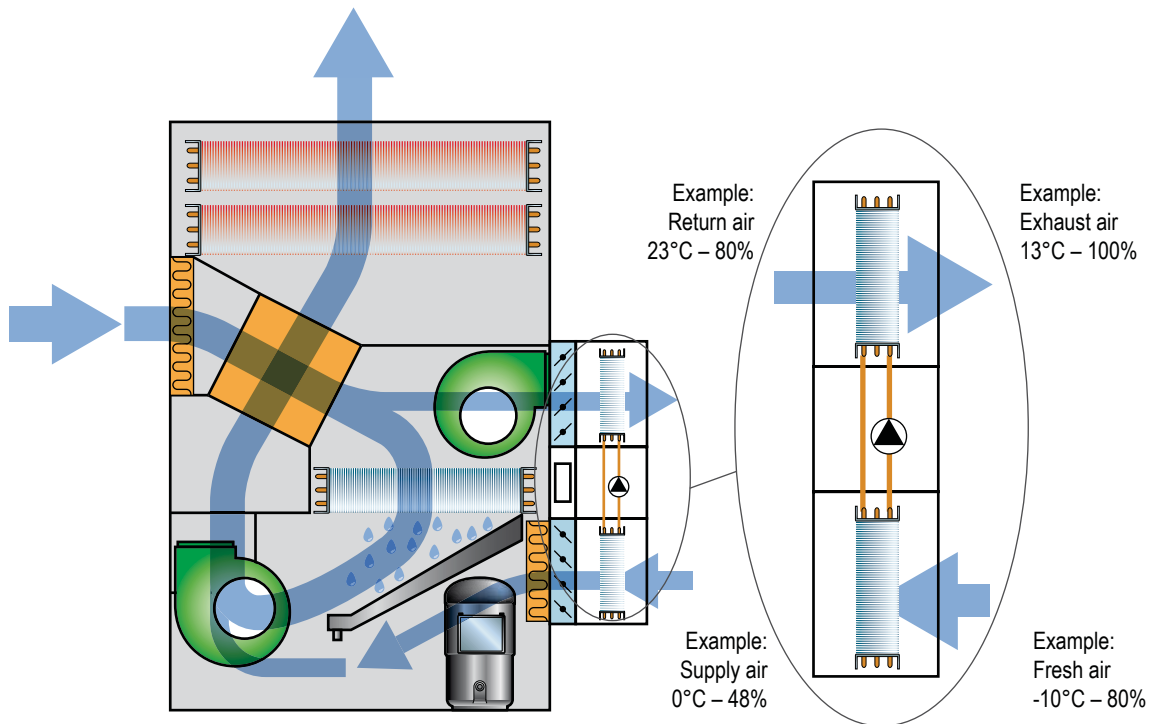

The device is managed by the unit microprocessor and it is factory set; The operation mode is the following: When the fresh air sensor measures a temperature lower than -5°C it is activated the water pump so the heat recovery function. The device is in operation until the fresh air temperature raises above the minimum set point temperature (set in the microprocessor). The microprocessor, with a compared measures of temperature and humidity sensors, provides to switch off the compressor in case the fresh air conditions are suitable to guarantee the required indoor conditions. In this way it is reduced the energy consumption of the unit that operates in FREE COOLING MODE.



The low ambient device is supplied in a separate box in the units UTA015 – 020; it is supplied incorporated in the main frame on the sizes UTA028-035-042-052-060.



The microprocessor is factory set in order to close the fresh air damper when the external temperature is lower than -30°C . In this case the unit operates in 100% recirculation air.

3.9 Operation limits

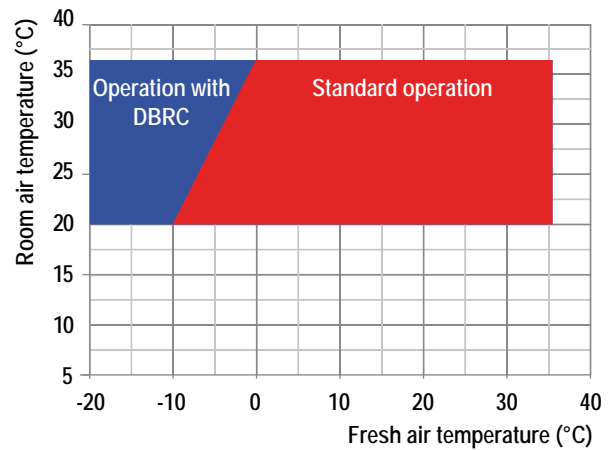
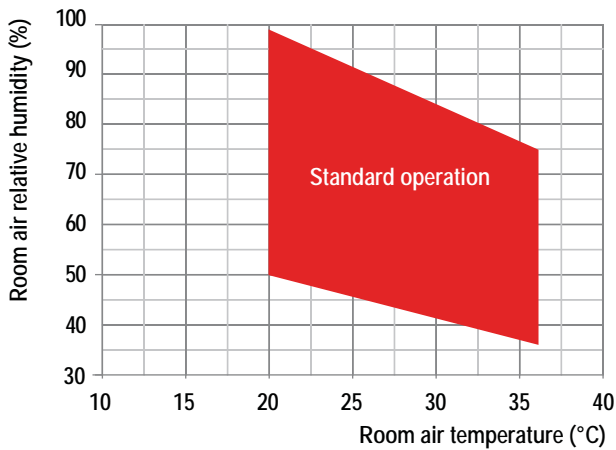

Units are designed and built to operate in heated technical rooms . The units are NOT suitable for external installation as this could form condensation on the walls of the unit and inside the electric panel with consequent damage of the unit.



Units are designed to operate with ambient temperatures from 10°C to 36°C, relative humidity from 50% to 99%; fresh air temperatures from -30°C up to 36°C.

3.9.1 Maximum pool water chlorine content

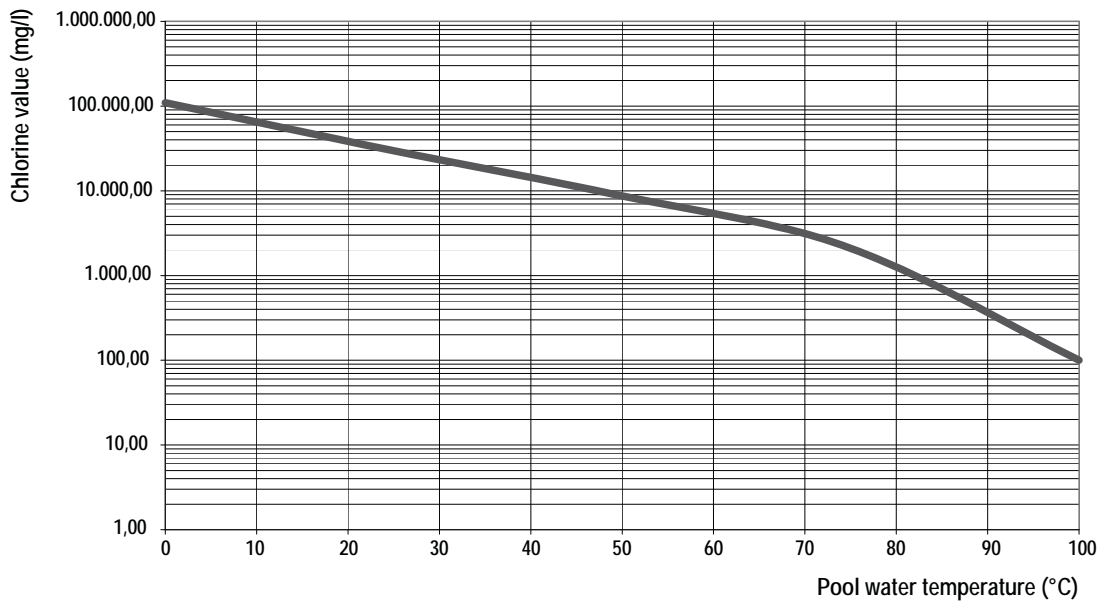

The units are designed and manufactured to operate with pool water chlorine values below the limits shown in the graph. Chlorine values above this limit can irreparably damage the unit.



The units **MUST** be used within the operation limit indicated in the diagrams (see above). the warranty will be invalidated if the units are used in ambient conditions outside the limits reported. If there is the necessity to operate in different conditions, please contact our technical office.

3.10 Sound data

The noise of the unit is mainly generated by the number of revolutions of the fans (responsible for the greater part of the sound power generated by the unit) . Obviously , for a given air flow rate , the number of revolutions of the fans will be lower if the required static pressure is low , while it will be higher (and therefore with greater noise level) in the case of higher static pressure demands.

Sound data											
Modd.	Octave band (Hz)								Lw		Lp
	63	125	250	500	1K	2K	4K	8K	dB	dB(A)	dB(A)
	dB	dB	dB	dB	dB	dB	dB	dB			
015	84,1	75,3	69,2	67,7	66,6	61,2	57,8	48,7	84,9	71	63
020	84,1	75,3	69,2	67,7	66,6	61,2	57,8	48,7	84,9	71	63
028	87,1	78,3	72,2	70,7	69,6	64,2	60,8	51,7	87,9	74	66
035	87,1	78,3	72,2	70,7	69,6	64,2	60,8	51,7	87,9	74	66
042	89,1	80,3	74,2	72,7	71,6	66,2	62,8	53,7	89,9	76	68
052	90,1	81,3	75,2	73,7	72,6	67,2	63,8	54,7	90,9	77	69
060	90,1	81,3	75,2	73,7	72,6	67,2	63,8	54,7	90,9	77	69

Lw: Sound power level according to ISO 9614.

Lp: Sound pressure level measured at 1 mt from the unit in free field conditions direction factor Q=2 according to ISO 9614.

3.11 Safety devices

3.11.1 High pressure switch

The high pressure switch stops the unit when the discharge compressor pressure is higher than the set value. The restart is automatic, done when the pressure is under the level set in the differential value.

3.11.2 Low pressure switch

The low pressure switch stops the unit when the evaporation pressure is lower than the set value. The restart is automatic and it is only possible when the pressure back over the value indicated by the differential set (see table below).

3.11.3 Defrost thermostat

It's a device which signals to the electronic control, the necessity to make the defrost cycle. Once the defrost cycle is activated, the defrost thermostat determines also its conclusion.

3.11.4 Defrosting

The frost on the coil, obstructs the air flow, reduces the available exchange area and consequently the unit performances and can seriously damage the system. All the units are supplied, standard, with a control which defrost automatically the heat exchanger if necessary. This control provides a temperature probe (defrost thermostat) on the unit evaporator. When the defrost cycle is required, the microprocessor control (according to set parameters), switches the compressor off, while the fan remains in operation. At the end of the defrost cycle, it is waited for the dripping time to allow the complete cleaning of the coil.

3.11.6 Electric data

Power supply	V/~/Hz	400 / 3 / 50
Auxiliary circuit	V/~/Hz	230 / 1 / 50

Control circuit	V/~/Hz	24 / 1 / 50
Fans power supply	V/~/Hz	400 / 3 / 50

4. INSTALLATION

4.1 General safety guidelines and use of symbols



Before undertaking any task the operator must be fully trained in the operation of the machines to be used and their controls. They must also have read and be fully conversant with all operating instructions.



All maintenance must be performed by TRAINED personnel and be in accordance with all national and local regulations.



The installation and maintenance of the unit must comply with the local regulations in force at the time of the installation.



Avoid contact and do not insert any objects into moving parts.

4.2 Health and safety Considerations



The workplace must be kept clean, tidy and free from objects that may prevent free movement. Appropriate lighting of the work place shall be provided to allow the operator to perform the required operations safely. Poor or too strong lighting can cause risks.



Ensure that work places are always adequately ventilated and that respirators are working, in good condition and comply fully with the requirements of the current regulations.

4.3 Personal protective equipment



When operating and maintaining the unit, use the following personal protective equipment listed below as required by law.



Protective footwear.



Eye protection.



Protective gloves.



Respiratory protection.



Hearing protection.

4.4 Inspection

When installing or servicing the unit, it is necessary to strictly follow the rules reported on this manual, to conform to all the specifications of the labels on the unit, and to take any possible precautions of the case. Not observing the rules reported on this manual can create dangerous situations. After receiving the unit, immediately check its integrity. The unit left the factory in perfect conditions; any eventual damage must be questioned to the carrier and recorded on the Delivery Note before it is signed. The company must be informed, within 8 days, of the extent of the damage. The Customer should prepare a written statement of any severe damage.

Before accepting the unit check:

- The unit did not suffer any damage during transport;
- The delivered goods are conforming to what shown in the delivery note.

In Case of Damage

- List the damage on the delivery note
- Inform the Company of the extent of the damage within 8 days of receipt of the goods. After this time any claim will not be considered.
- A full written report is required for cases of severe damage.

4.5 Storage

Units should be stored under cover and ideally, should remain in their packaging. The tools that are supplied for opening the electric box should be formally transferred to the person responsible for the plant.

4.6 Unpacking



Packaging could be dangerous for the operators.

It is advisable to leave packaged units during handling and remove it before the installation. The packaging must be removed carefully to prevent any possible damage to the machine. The materials constituting the packaging may be different in nature (wood, cardboard, nylon, etc.).



The packaging materials should be separated and sent for disposal or possible recycling to specialist waste companies.

4.7 Lifting and handling

When unloading the unit, it is highly recommended to avoid any sudden move in order to protect refrigerant circuit, copper tubes or any other unit component. Units can be lifted by using a forklift or, in alternative, using belts, being sure that the method of lifting does not damage the lateral panels and the cover. It is important to keep the unit horizontal at all time to avoid damages to the internal components.

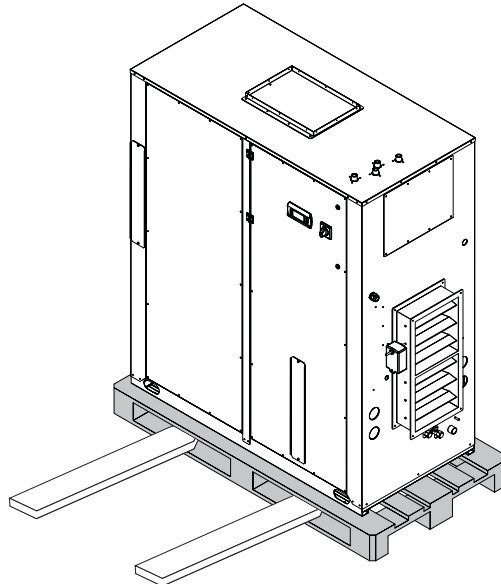

4.8 Location and minimum technical clearances



The unit has to be installed such that maintenance and repair is possible. The warranty does not cover costs for the provision of lifting apparatus, platforms or other lifting systems required to perform repairs during warranty period.



The installation site should be chosen in accordance with EN 378-1 and 378-3 standards. When choosing the installation site, all risks caused by accidental refrigerant leakage should be taken into consideration.

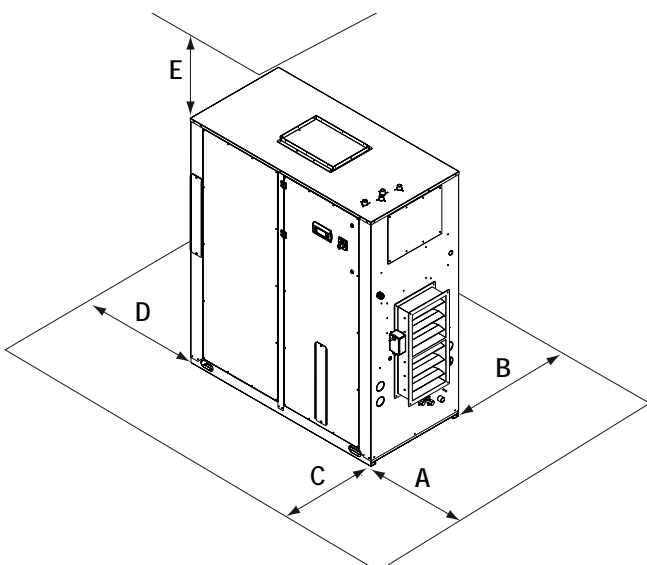

Mod.	A	B	C	D	E
015	500	800	400	500	600
020	500	800	400	500	600
028	500	800	400	500	800
035	500	800	400	500	800
042	500	800	400	500	800
052	500	800	400	500	800
060	500	800	400	500	800



In the main european markets, the minimum distance of electric appliances from water sources (basins, showers, pools, whirlpools) is 2 meters! Before the installation of the unit it is compulsory to check the national or local norms.

4.9 Condensate draining connections

Condensate draining should be done with a rubber pipe passing through the condensate draining connection located on the suction side of the unit. The discharge hole is positioned inside the unit and with a 3/4" female thread diameter. On the condensate discharge pipe it must be installed a siphon with a minimum height equal to the suction pressure of the fan.

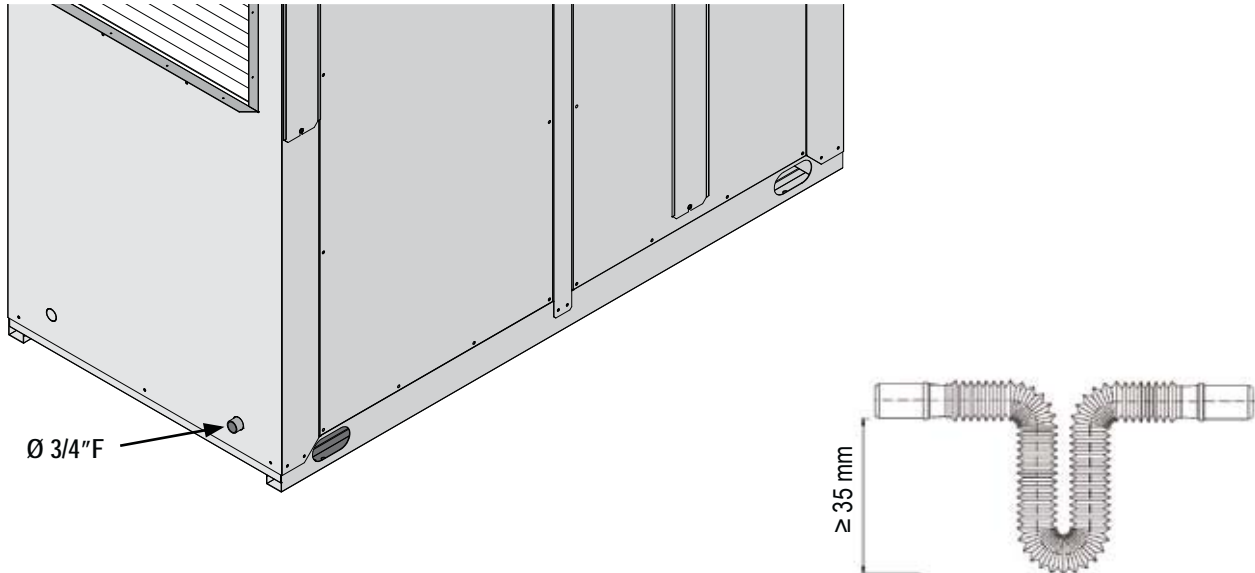

The condensate drain line should have a water trap which may have minimum flying height equal to the suction of the fan, in any case never less than 35 mm.

4.10 Ductwork unit connection

All the units are provided with 2 centrifugal fans, both can be ducted. All units are equipped with ductable centrifugal fans. Connect the duct to the appropriate flanges supplied with the unit using a flexible joint to reduce the transmission of vibration and noise in the room.

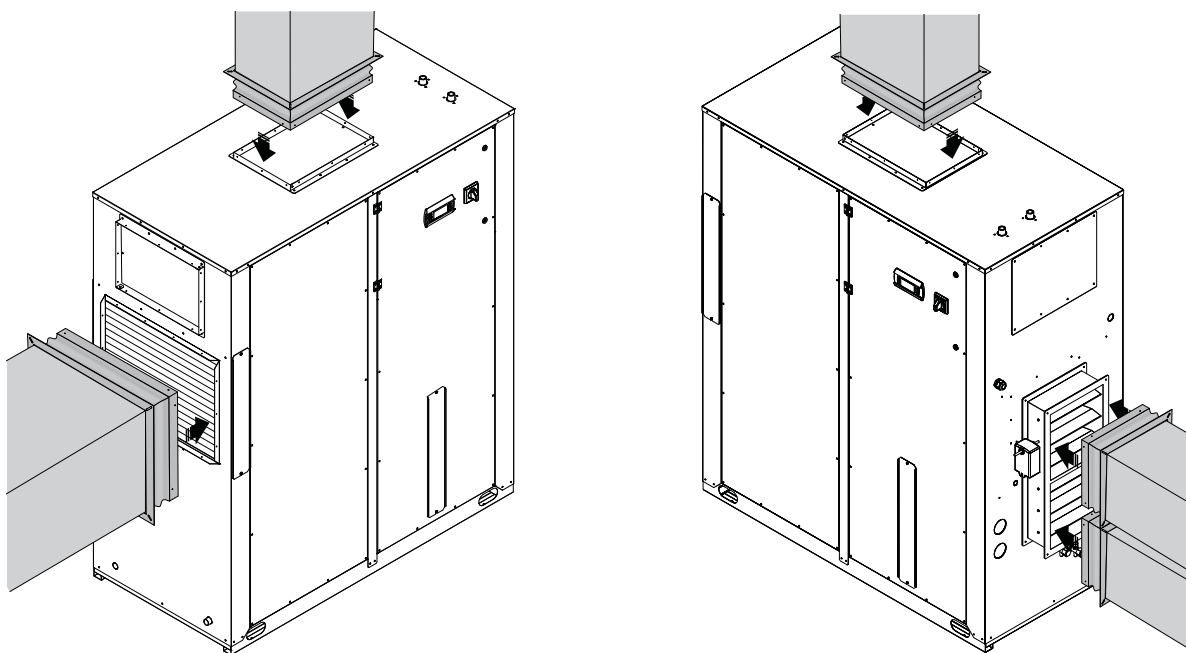

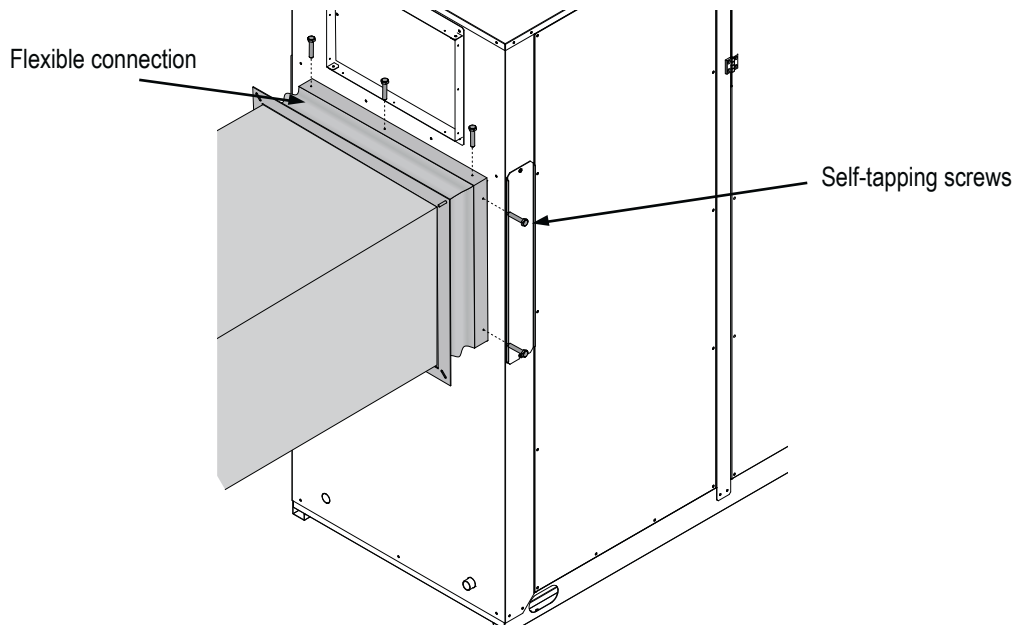

Air duct fixing at the supply and return ports



In order to enable the proper functioning of the unit is important to ensure a constant air flow to the unit close to the nominal stated value. The maximum deviation allowed is 10%.



In order to limit the noise, it is necessary that the air speed inside ducts would never exceed 4 m / sec. With crossing high speed, it greatly reduces the dehumidification capacity of the unit and increases the risk of dragging of water condensation in the air ducts with a potential damage to the furniture and / or flooring.



It is always recommended to use a flexible connection between the unit and air distribution system (duct channel) in order to reduce the transmission of vibrations



In order to enable the proper functioning of the unit is important to ensure a constant air flow to the unit close to the nominal stated value. The maximum deviation allowed is 10%. The maximum allowed deviation is 10%. When commissioning the unit check the air flow rates and modify, if necessary, the calibration of the fans in accordance with the system needs (useful channel length / head required).



When ductworks are connected it is **IMPORTANT** to check if the airspeed through the evaporator is around 1,5÷ 2 m/s. This parameter allow the unit to operate with the maximum efficiency; so an airspeed over than 2 m/s should never been exceeded.

4.11 Installation of built-in room electronic sensor (RGDD)

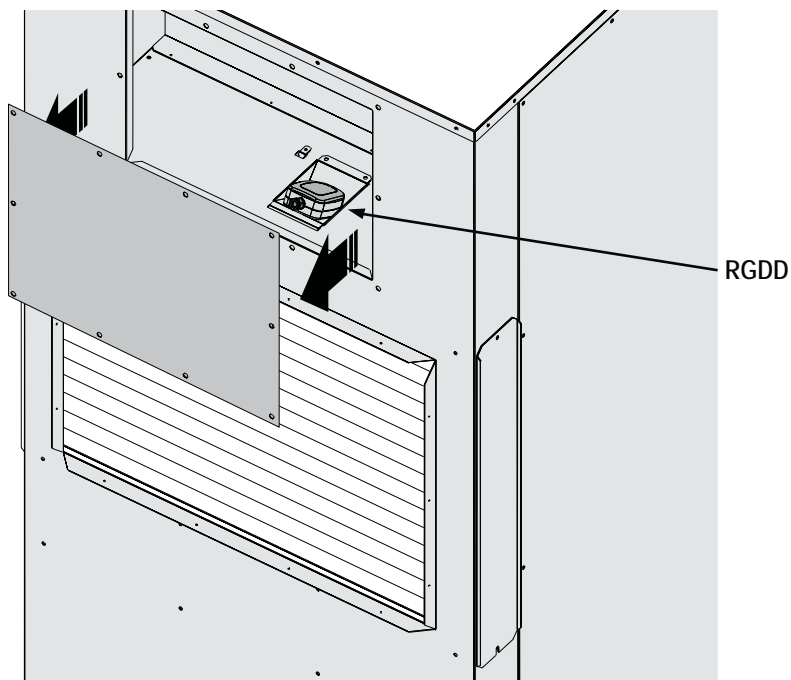

4.12 How to remove filters

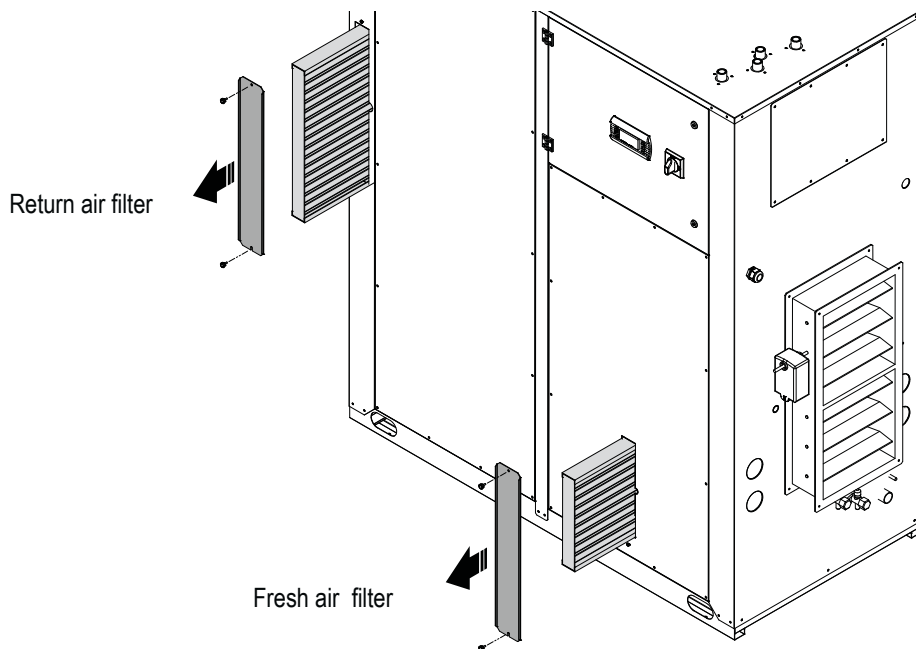

4.11 Partial heat recovery hydraulic connections (option)



The partial heat recovery coil must always be installed downstream of the water filter and upstream of the water disinfection treatment in the pools hydraulic circuit. The positioning of the heat exchanger upstream of the disinfection treatment is important because prolonged exposure to high concentrations of disinfectants chemicals can cause irreparable damage to the heat recovery coil. Downstream of the disinfection system has generally much higher concentration of disinfectants than in the pool. It's also important for the partial heat recovery coil to be positioned upstream of the filter, so that any debris from the pool do not pass into the coil. Which can cause poor performance of the coil and damage!

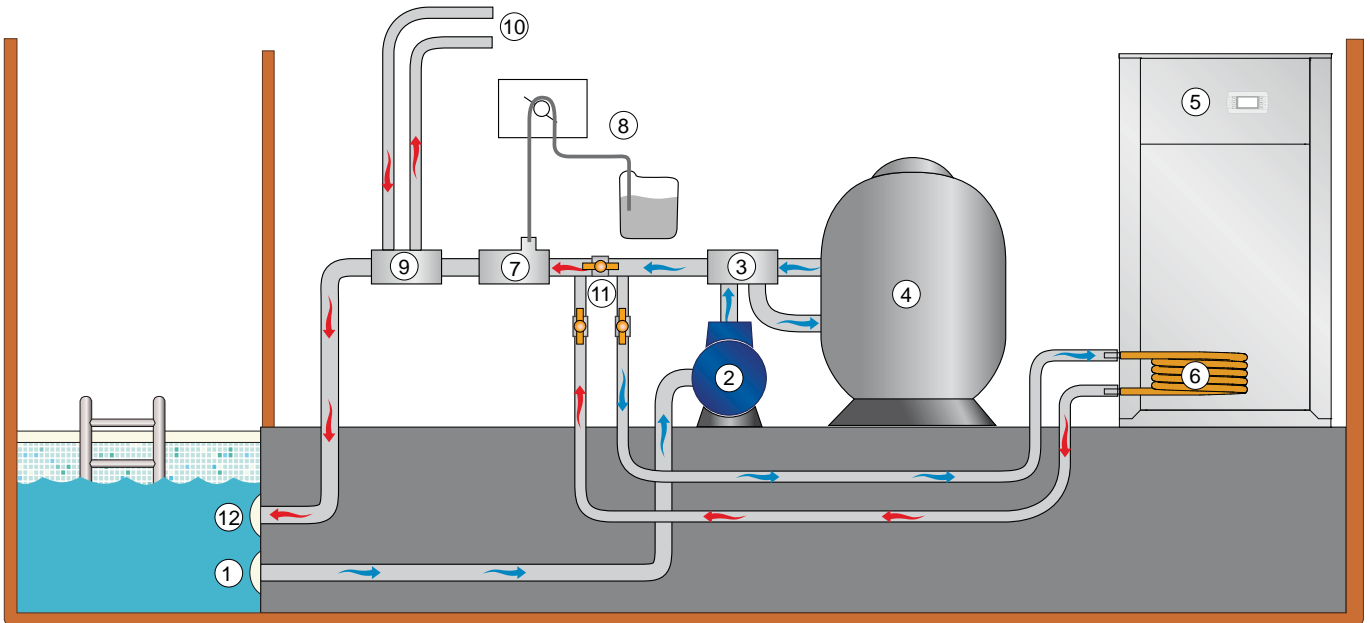

1	Water pool return	7	Pool water disinfection treatment
2	Pool water pump	8	Pool water disinfection dosing system
3	Pool water valve	9	Pool water heating system
4	Pool water filter	10	To the pool water heating system (Boiler, heat pump, etc.)
5	UTA dehumidifier	11	Pool water valves adjustment set
6	UTA Partial heat recovery	12	Water pool supply



Never positioning the partial heat recovery downstream of the water disinfection treatment.



The partial heat recovery is managed by the unit microprocessor. When the ambient temperature increases, the control activates a contact for the partial heat recovery water pump starting or the valve opening (both components are not included).



Guarantee will be invalidated if the instructions present in this manual will not be strictly followed.

4.12 Hot water coil hydraulic connections

All the units are provided with hot water coil; the hydraulic connections are 3/4" female threaded type. Hot water coil allows swimming pool air heating. The hot water coil is supplied with 3 way modulating valve (controlled by the unit microprocessor). In the hot water coil hydraulic circuit a water pump should be present (not included in the unit supply).

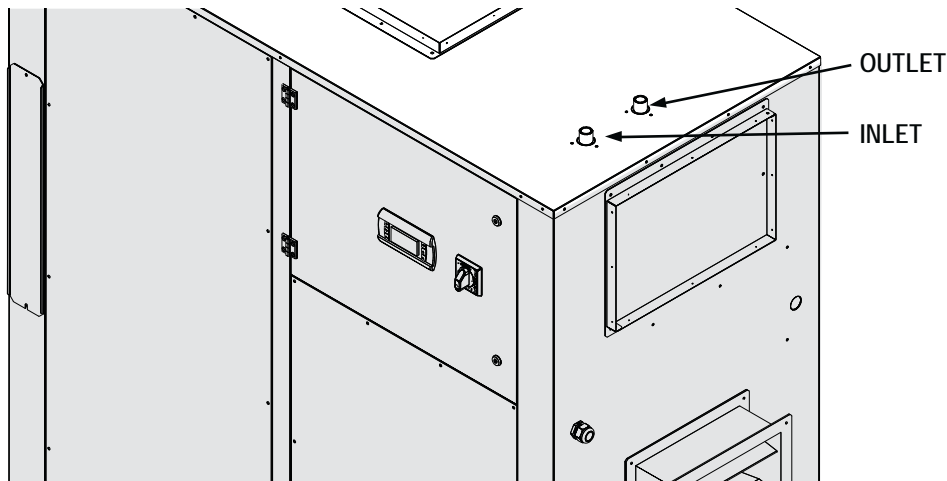

4.13 Refrigerant connections for Z version

The Z version units are supplied of a remote condenser and they need to be connected with the dehumidifier through refrigerant lines. The remote condenser is equipped with a main switch and a fan speed control. Please refer to the following paragraphs for the refrigerant connections and to the next chapter for the electrical ones.

4.13.1 Line path and max distance between the sections

For the units in Z version with separate sections, the course of the refrigerant pipes is influenced by the location of the sections themselves and by the structure of the building. The pipes have to be in any case as short as possible, so that they can contain the charge lacks and reduce the quantity of refrigerant present in the refrigerant circuit. The connections must be isolated and their length must not exceed 30 meters.

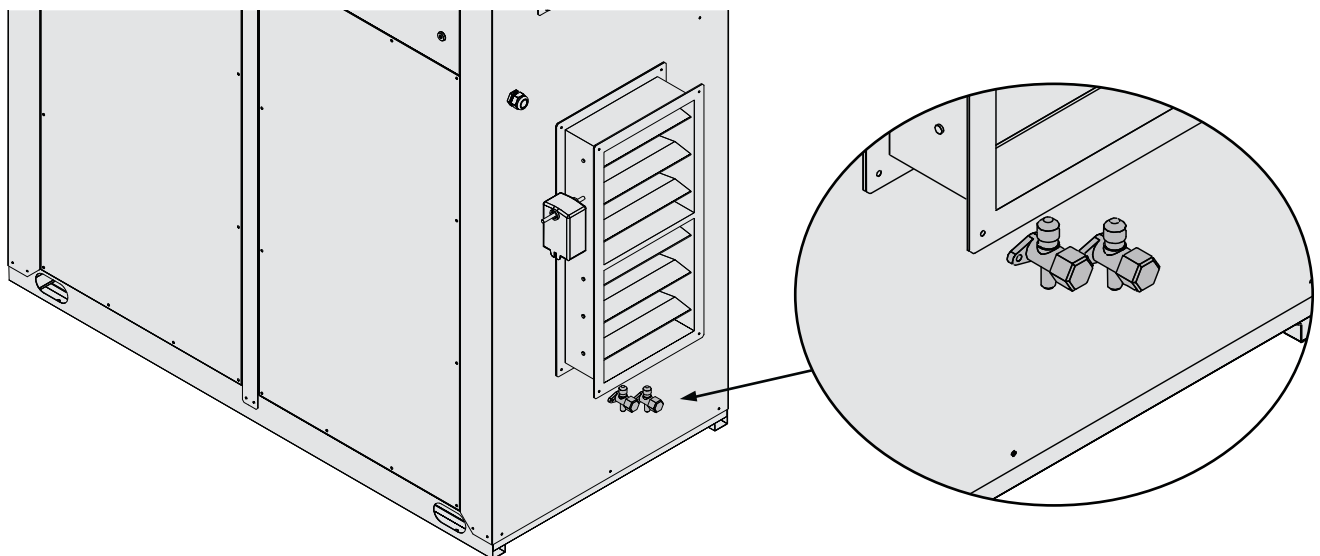

4.13.2 Dehumidifier higher than the condenser

- On the rising vertical pipes, oil traps should be fitted every 6 meters to allow oil circulation in the system. On horizontal suction pipelines a minimum 1% slope should be allowed in order to let the oil easily come back to compressor.
- Pipelines diameter can be read in the Table depending on the unit size and on the length of refrigerant pipelines.

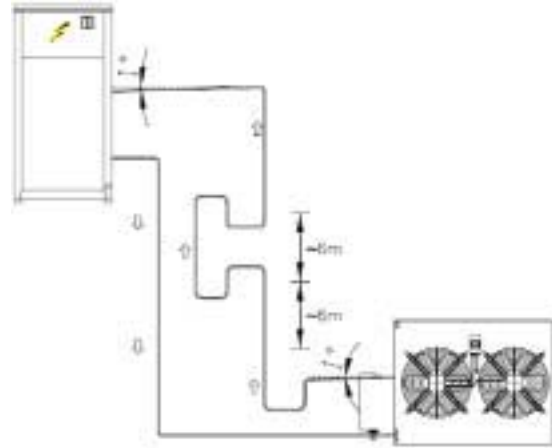

4.13.3 Dehumidifier lower than the condenser

- Install a liquid trap on suction line at the evaporator outlet with the same height of the evaporator so that liquid refrigerant, when the system is not running, will not fall into compressor.
- On horizontal suction pipelines a minimum 1% slope be allowed in order to let the oil easily come back to compressor.

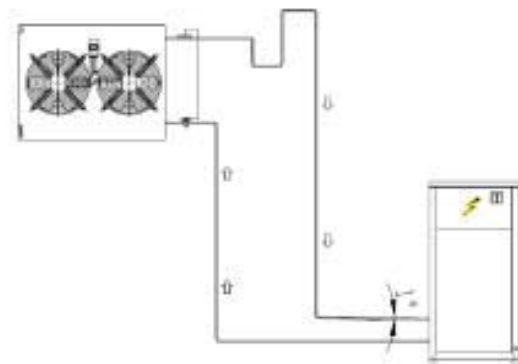

4.14 Refrigerant diameters lines for version UTAZ

Distance [m]	10		20		30	
	Gas [mm]	Liquid [mm]	Gas [mm]	Liquid [mm]	Gas [mm]	Liquid [mm]
015	10	10	10	10	10	10
020	10	10	12	10	12	10
028	12	12	12	12	12	12
035	16	12	16	12	16	12
042	16	16	16	16	16	16
052	18	16	18	16	18	16
060	18	16	18	16	18	16

4.14.1 Liquid line refrigerant charge

Liquid line diameter	Liquid line refrigerant charge [g/m]	Liquid line diameter	Liquid line refrigerant charge [g/m]
8 (mm)	30	16 (mm)	175
10 (mm)	50	18 (mm)	220
12 (mm)	84	22 (mm)	360

4.14.2 Cooling capacity correction factor

Mod	Refrig. line 0 mt.	Refrig. line = 10 mt.	Refrig. line 20 mt.	Refrig. line 30 mt.
UTAZ	1	0,98	0,96	0,95

4.15 Electric connections: preliminary safety information

The electric panel is located inside the unit at the top of the technical compartment where the various components of the refrigerant circuit are also to be found. To access the electrical board, remove the front panel of the unit:



Power connections must be made in accordance to the wiring diagram enclosed with the unit and in accordance to the norms in force.



Make sure the power supply upstream of the unit is (blocked with a switch). Check that the main switch handle is padlocked and it is applied on the handle a visible sign of warning not to operate.



It must be verified that electric supply is corresponding to the unit electric nominal data (tension, phases, frequency) reported on the label in the front panel of the unit.



Power cable and line protection must be sized according to the specification reported on the form of the wiring diagram enclosed with the unit.



The cable section must be commensurate with the calibration of the system-side protection and must take into account all the factors that may influence (temperature, type of insulation, length, etc.).



Power supply must respect the reported tolerances and limits: If those tolerances should not be respected, the warranty will be invalidated.



Make all connections to ground provided by law and legislation.



Before any service operation on the unit, be sure that the electric supply is disconnected.



FROST PROTECTION

If opened, the main switch cuts the power off to any electric heater and antifreeze device supplied with the unit, including the compressor crankcase heaters. The main switch should only be disconnected for cleaning, maintenance or unit reparation.

4.16 Electrical data



The electrical data reported below refer to the standard unit without accessories.
In all other cases refer to the data reported in the attached electrical wiring diagrams.



The line voltage fluctuations can not be more than $\pm 10\%$ of the nominal value, while the voltage unbalance between one phase and another can not exceed 1%, according to EN60204. If those tolerances should not be respected, please contact our Company.

Model		015	020	028	035	042	052	060
Power supply	V/~/Hz	400/3+N/50	400/3+N/50	400/3+N/50	400/3+N/50	400/3+N/50	400/3+N/50	400/3+N/50
Control board	V/~/Hz	24 V	24 V	24 V	24 V	24 V	24 V	24 V
Auxiliary circuit	V/~/Hz	230/1/50	230/1/50	230/1/50	230/1/50	230/1/50	230/1/50	230/1/50
Fans power supply	V/~/Hz	230/1/50	230/1/50	230/1/50	230/1/50	230/1/50	230/1/50	230/1/50
Line section	mm ²	6	6	6	6	10	10	10
PE section	mm ²	6	6	6	6	10	10	10



Electric data may change for updating without notice. It is therefore necessary to refer always to the wiring diagram present in the units.

4.19 How to connect the power supply

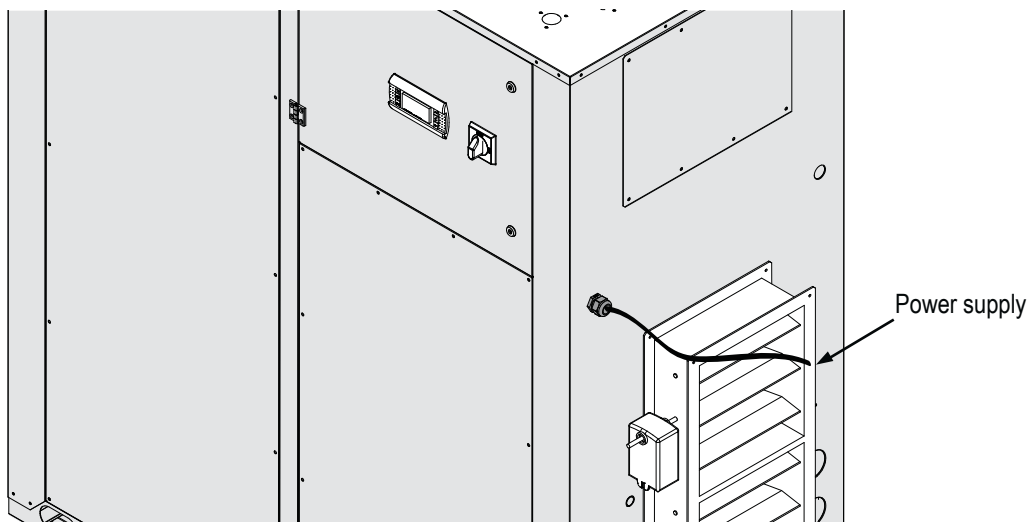

4.17 Electric connections



The numbering of the terminals may change without notice. For their connection is mandatory to refer to the wiring diagram supplied along with the unit.

4.17.1 Remote wiring connections (compulsory)

All terminals referred to in the explanations below will be found on the terminal board inside the electrical box. All electric connections mentioned below have to be made by the installer, on site.

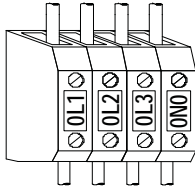

UNITS POWER SUPPLY

The units are supplied with 400V / 3 + N/50Hz voltage , it is highly recommended to interpose a main switch on the power line. Please refer to the wiring diagram for the correct sizing.

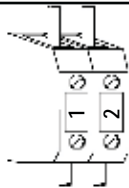

REMOTE ON / OFF

To switch the unit on or off from remote control.

Contacts are voltage free.

Le unità sono fornite di serie dalla fabbrica con morsetti ponticellati.

Contact closed, unit ON,

Contact open, unit OFF.

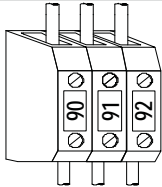

REMOTE GENERAL ALARM

For remote display of a general alarm, connect the visual or audible device between terminals 90-91-92.

Contacts 90/91 NC (Normally closed)

Contacts 91/92 NO (Normally opened)

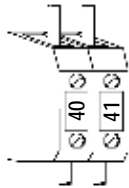

PUMP HOT WATER COIL

Free contact (2A max) for inductive loads.

It,s connected between terminals 40 and 41.

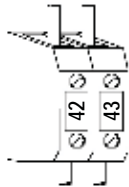

LOW AMBIENT TEMPERATURE DEVICE (DBRC)

Free contact (2A max) for inductive loads.

It,s connected between terminals 42 and 43.

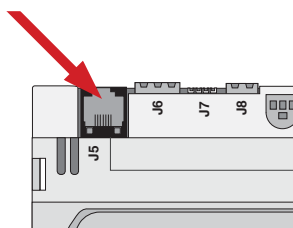

REMOTE CONTROL PANEL

The remote control panel replicates all of the functions on the main controller panel and can be connected up to a maximum distance of 50 meters from the unit. The panel has to be connected to the unit by telephone cable. The power supply cables must be separated from the remote control panel wires, in order to avoid interference.

The control panel cannot be installed in an area subject to excessive vibration, corrosive gases, is a dirty environment or has a high humidity level. The ventilation openings must not be blocked.

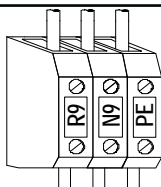

REMOTE CONDENSER (ONLY FOR UTAZ)

It,s connected between terminals R9, N9 and PE.

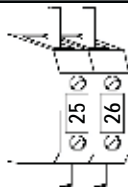

PARTIAL HEAT RECOVERY PUMP

Free contact (2A max) for inductive loads.

It,s connected between terminals 25 and 26.

4.18 Fans

4.18.1 Supply Fan speed regulation

All units are factory set with UTA values of nominal airflow and external static pressure (please read specific table at paragraph 3.7). The air flow volume can be modified only through the maintenance menu.

4.18.2 Exhaust Fan speed regulation

All units are factory set with UTA values of nominal airflow and external static pressure (please read specific table at paragraph 3.7). The air flow volume can be modified only through the maintenance menu.

5. UNIT START UP

5.1 Preliminary checks

Before starting the unit the checks detailed in this manual of the electric supply and connections, the hydraulic system and the refrigerant circuit, should be performed.



Start-up operations must be performed in accordance with the instructions detailed in the previous paragraphs.

5.1.1 Before start-up



Damage can occur during shipment or installation. It is recommended that a detailed check is made, before the installation of the unit, for possible refrigerant leakages caused by breakage of capillaries, pressure switch connections, tampering of the refrigerant pipework, vibration during transport or general abuse suffered by the unit.

- Verify that the unit is installed in a workmanlike manner and in accordance with the guidelines in this manual.
- Check that all power cables are properly connected and all terminals are correctly fixed.
- The operating voltage the one shown on the unit labels.
- Check that the unit is connected to the system earth.
- Check that there is no refrigerant leakage.
- Check for oil stains, sign of a possible leak.
- Check that the refrigerant circuit shows the correct standing pressure on the pressure gauges (if present) otherwise use external ones.
- Check that the Schrader port caps are the correct type and are tightly closed.
- Check that crankcase heaters are powered correctly (if present).
- Check that all water connections are properly installed and all indications on unit labels are observed.
- The system must be flushed, filled and vented in order to eliminate any air.
- Check that the water temperatures are within the operation limits reported in the manual.
- Before start up check that all panels are replaced in the proper position and locked with fastening screws.



Do not modify internal wiring of the unit as this will immediately invalidate the warranty.

5.2 Description of the control panel

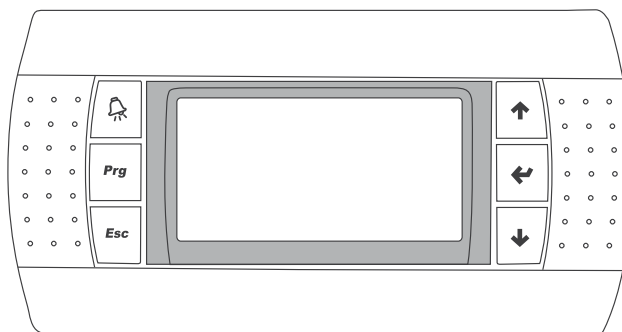

5.2.1 Key function

	It is used to display the alarms, mutes the buzzer.
Prg	It is used to display / program the unit parameters.
Esc	Menu exit.
	Menu Scroll up and/or variable settings.
	Enter
	Menu Scroll down and/or variable settings.

5.3 Description of the remote control panel

5.3.1 Dimensions

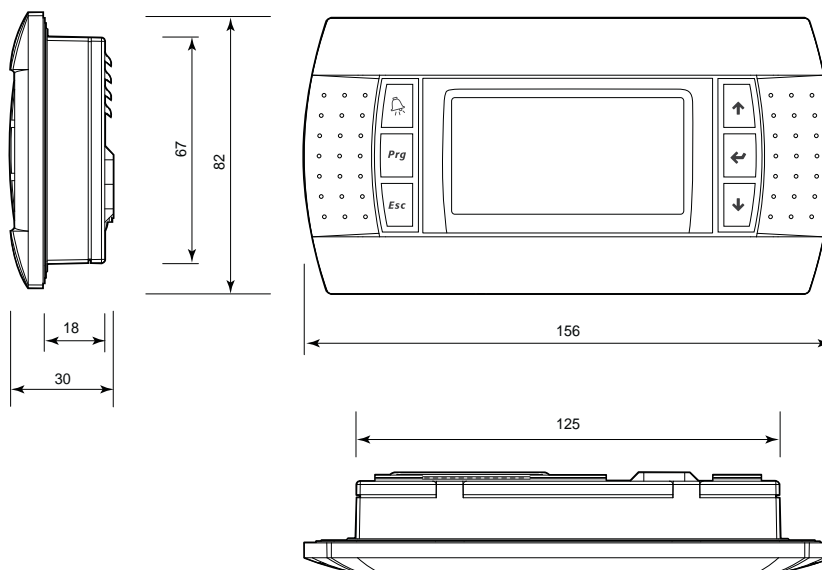

5.3.2 Wall-mounting

The wall-mounting of the terminal first requires the back piece of the container (A) to be fitted, using a standard three-module switch box.

- Fasten the back piece to the box using the rounded-head screws supplied in the packaging;
- Connect the telephone cable;
- Rest the front panel on the back piece and fasten the parts together using the flush-head screws supplied in the packaging, as shown in figure;
- Finally, fit the click-on frame.

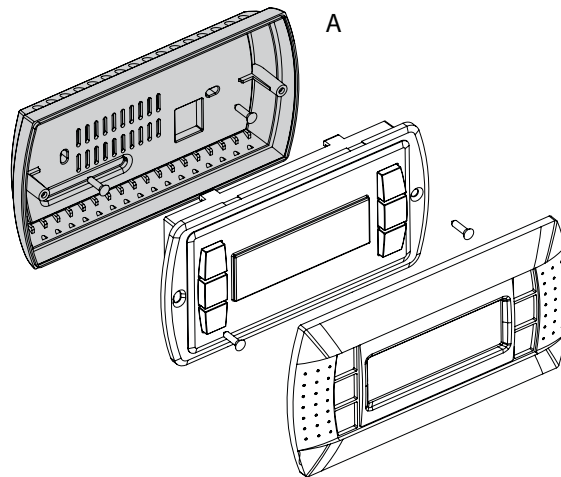

5.3.3 Electrical connection

Connect the telephone cable from the board to the connector provided on the rear of the terminal.

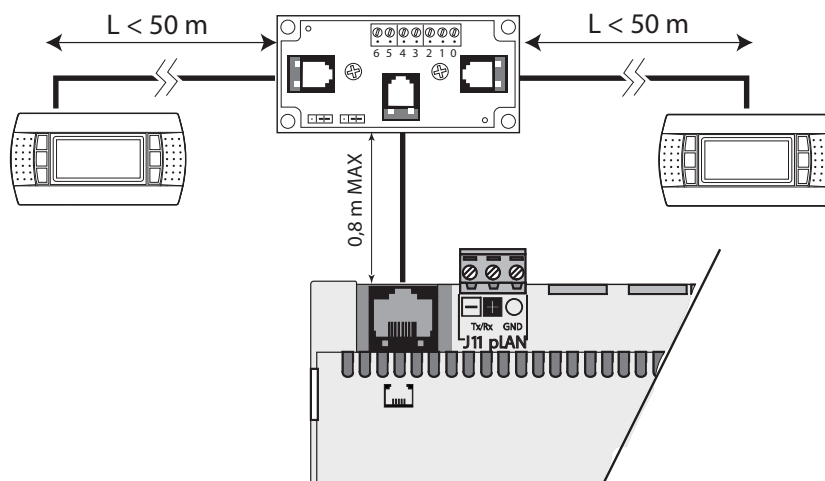

Electric data can be updated without notice. It is therefore necessary to always refer to the wiring diagram provided in the unit.



If there is damage to the remote control or there is a faulty connection, failure of communication will be indicated in the display with the message “noL” (no link).

6. USE

6.1 Unit On/Off

Unit On/Off can be done trough

- Keyboard
- Remote ON/OFF

6.1.1 Switching on from Keyboard

To switch on the unit, press at the same time **↑** and **↓** keys. The display visualization will be the following:

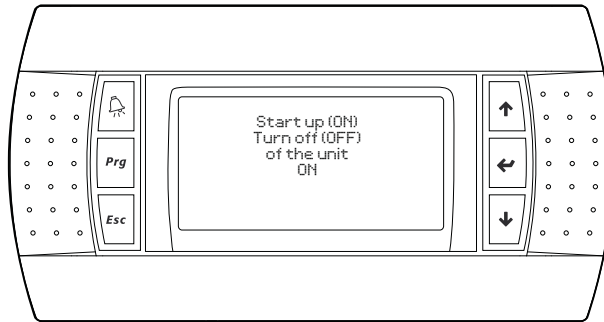

The cursor will be positioned onto On Off. With **↑** and **↓** keys choose the desired modality and then press **←** key to confirm.

6.1.2 Switching on by remote

To switch on the unit proceed as described in the previous paragraph. Now would be possible to activate and disable unit remotely. The control display would show "Off by remote"

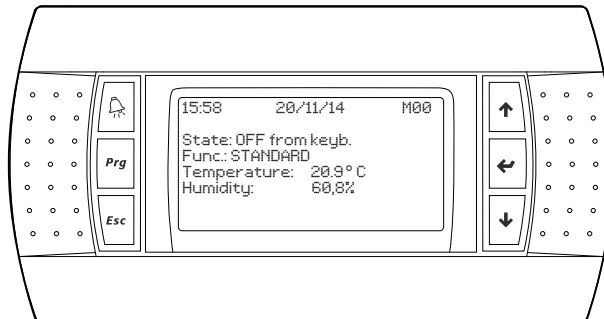

6.1.3 These are the main visualisations:

From the main screen by pressing **↓** it is possible to scroll up/down some principal parameters of the system:

<pre>00:00 00/00/00 M00 State: Unit ON Func.:STANDARD + FRESH AIR Temperature : 27.4 °C Humidity : 56.5% Fresh air : ON</pre>	<p>To start the unit, close the main switch; on the display of the microprocessor will appear the following screen. Press at the same time the buttons ↑ and ↓ Press ON to start</p>
<pre>00:00 00/00/00 M01 Fresh air :17.0 °C Discharge air :12.3 °C Dew point Temp. :13.0 °C Fr.air.crit.T.:-14.4 °C</pre>	<p>Reading only: shows the status of the component.</p>

<pre>00:00 00/00/00 M02 Compressor : OFF Primary Fan: ON Desuperheater : OFF Desuper. pump.: OFF Hot water pump.: OFF Hot water valv : 36.6%</pre>	<p>Reading only: shows the status of the component.</p>
<pre>00:00 00/00/00 M03 Rem.cond. Valv. : OFF Return fan : 065.0% Fresh air fan : 065.0% Fresh air damp.: 100.0%</pre>	<p>Reading only: shows the status of the component.</p>
<pre>00:00 00/00/00 M04 Mode: EN.SAVING Source : DIGIT. INP. Operation : STANDARD Temp. Set: SECONDARY Humid. Set: SECONDARY</pre>	<p>Reading only: shows the status of the component.</p>

6.2 Main menu

From the main screen by pressing **Prg** it is possible to see available menu:

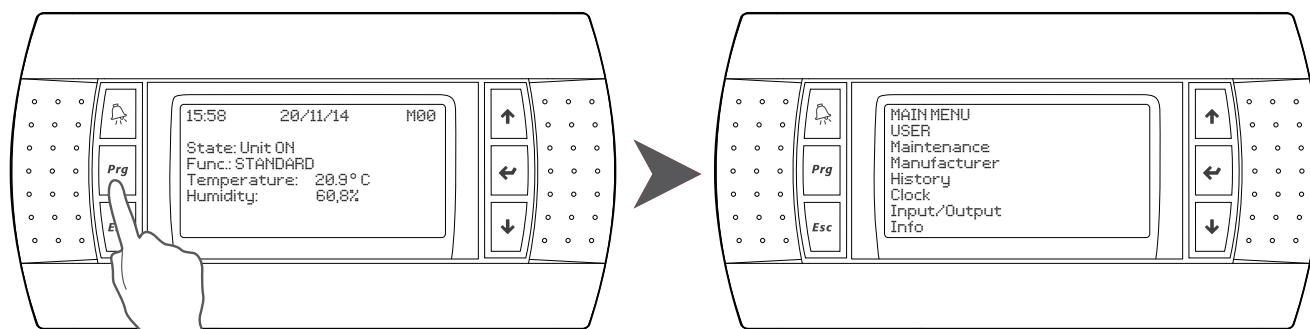

With **↓** and **↑** keys it is possible to navigate inside menu directories. Select the required one then press **←**.

6.2.1 Working modality:

- **STANDARD + FRESH AIR:** This modality enables the refrigerant system and the fresh air; this mode is used in the periods of medium or high crowding and when it's necessary the integration of fresh air.
- **STANDARD:** This modality enables the refrigerant system for dehumidification without fresh air; This mode is used when the fresh air is not required.
- **VENTILATION + FRESH AIR:** This mode allows the unit to operates in ventilation (compressor does not work) with the use of fresh air; in this case the dehumidification is given by fresh air only; This modality is used when the value of humidity to be removed is not very high.
- **VENTILATION :** This modality allows the unit to work in ventilation (compressor will never start), without fresh air; in this modality dehumidification will not be possible. This modality is used when the unit works on heating only.
- **OFF:** In this modality the unit is in stand-by.

The combination of the modalities reported above with the choice of the desired set point (MAIN , SECONDARY), determines the various configurations of the unit;

6.3 User menu

From the main screen by pressing **Prg** it is possible to show the available menu:

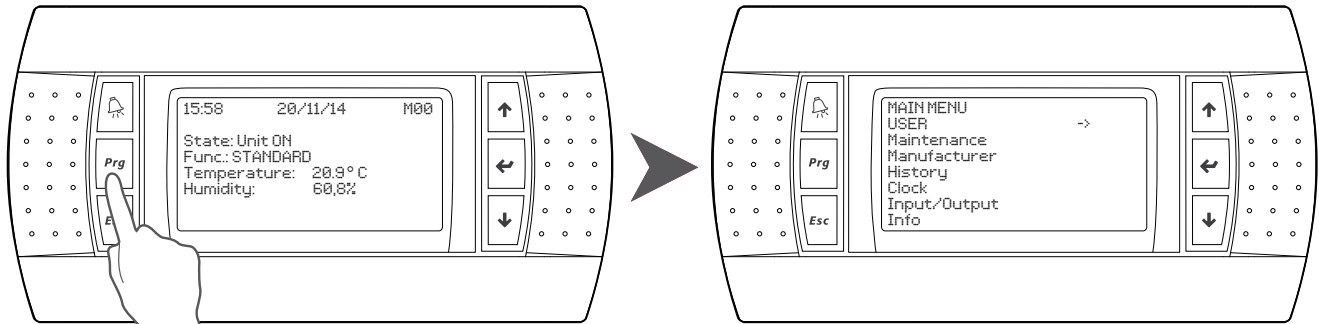

With **↓** and **↑** keys it is possible to navigate inside menu directories. Select the required one then press **←**.

The UTA units can operate with different SET POINT levels (Temperature and humidity):

- MAIN Set point: it's used when the swimming pool is normally or over crowded.
- SECONDARY Set point: it's used when the swimming pool is closed or not crowded.





<p>P01</p> <p>MAIN REGULATION</p> <p>Temperature main set-point: 30.0°C</p> <p>Humidity main set-point: 60.0%</p>	<p>Set the temperature and the humidity required.</p> <p>Press ENTER to activate the field.</p> <p>select with ↑ and ↓ and press ENTER to confirm.</p>
<p>P02</p> <p>SECONDARY REGULATION</p> <p>Temperature secondary set-point: 23.0°C</p> <p>Humidity secondary set point: 70.0%</p>	<p>Set the temperature and the humidity required.</p> <p>Press ENTER to activate the field.</p> <p>select with ↑ and ↓ and press ENTER to confirm.</p>
<p>P03</p> <p>DEW POINT</p> <p>Return air</p> <p>Temperature: 30.0°C</p> <p>Humidity : 60.0%</p> <p>Dew Point: 21.3°C</p>	<p>Reading only:</p> <p>shows the temperature of the ambient return air and determines the dew point .</p>
<p>P04</p> <p>FRESH AIR PROBE</p> <p>Temperature: 31.0°C</p> <p>DISCH. AIR PROBE</p> <p>Temperature: 33.9.0°C</p>	<p>Reading only:</p> <p>shows the temperature of ambient discharge air and of the fresh air.</p>
<p>P05</p> <p>FRESH AIR CRITICAL TEMPERATURE</p> <p>Temperature: 00.0°C</p>	<p>Reading only:</p> <p>shows the temperature of the fresh air under which the recovery is de-activated and the unit starts working 100% re-circulation.</p>
<p>P06</p> <p>TIME ZONES</p> <p>Enable unit management according to time zones?</p> <p style="text-align: right;">YES/NO</p>	<p>Enables the operation of the unit by time settings (slots). In this way, the operating mode will be enabled at certain times and set in the subsequent screens. In this case would not be enabled the operation time slot, the unit will be forced to operate "OUT OF RANGE" and only in those one set in the mask A15.</p>
<p>P07..... P13</p> <p>TIME ZONES MANAGEMENT</p> <p>MONDAY - SUNDAY</p> <p>09:00 - 12:00 COMFORT</p> <p>14:00 - 22:00 HEATING</p> <p>00:00 - 00:00 OFF</p>	<p>Enable the daily and weekly times zones to enable the unit to work.</p> <p>Select ↑ and ↓ and press ENTER to confirm.</p>

6.3.1 Settings the fan speed

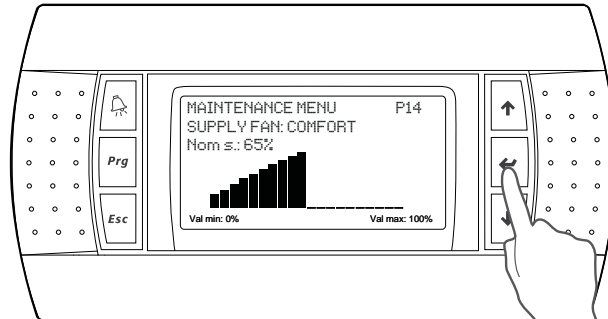
Both for the main and fresh air fan it is possible to set the operation speed in the different operation modes.

To set the speed of the fans, proceed as follows:



With  key it is possible to select the parameter to edit then press  and  to set the required value. Press  again to confirm.

P14	SUPPLY FAN: COMFORT Nom s.:065% min:000% max:100%	Enable to set the supply fan speed in the different working modes.
P15	SUPPLY FAN: ENRG SAVING Nom s.:065% min:000% max:100%	Enable to set the supply fan speed in the different working modes.
P16	SUPPLY FAN: NIGHT Nom s.:065% min:000% max:100%	Enable to set the supply fan speed in the different working modes.
P17	SUPPLY FAN: FREE COOL. Nom s.:065% min:000% max:100%	Enable to set the supply fan speed in the different working modes.
P18	SUPPLY FAN: N.ZONES Nom s.:065% min:000% max:100%	Enable to set the supply fan speed in the different working modes.
P19	EXHAUST F.: COMFORT Nom s.:065% min:000% max:100%	Enable to set the exhaust fan speed in the different working modes.
P20	EXHAUST F.: ENRG SAVING Nom s.:065% min:000% max:100%	Enable to set the exhaust fan speed in the different working modes.
P21	EXHAUST F.: NIGHT Nom s.:065% min:000% max:100%	Enable to set the exhaust fan speed in the different working modes.

<p>P22</p> <p>EXHAUST F.: FREE COOLING Nom s.:065% min:000% max:000%</p>	<p>Enable to set the exhaust fan speed in the different working modes.</p>
<p>P23</p> <p>EXHAUST F.: T.ZONES Nom s.:065% min:000% max:000%</p>	<p>Enable to set the exhaust fan speed in the different working modes.</p>
<p>P24</p> <p>CHOOSE LANGUAGE LANG.: English</p>	<p>Enable language selection; Select ↑ and ↓ and press ENTER to confirm.</p>

Press **Esc** key to back to the main menu.

6.4 Maintenance menu

From the main screen press **Prg** to display the available menu:

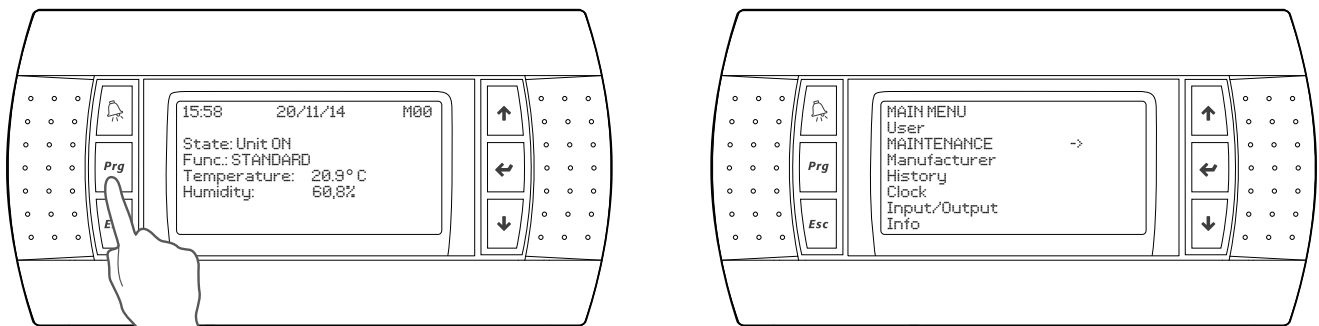

With ↓ and ↑ keys it is possible to navigate inside menu directories. Once chosen the desired one press ←.

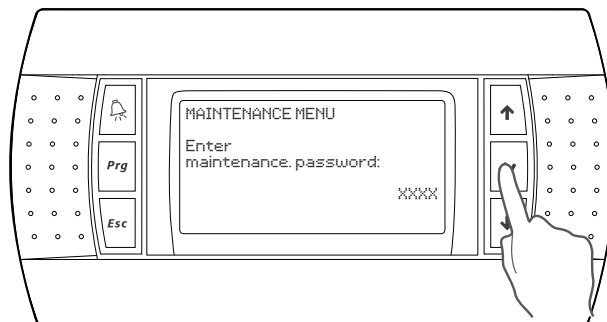

With ↓ and ↑ keys it is possible to select the password. Press ← to confirm.

<p>A01</p> <p>DEW POINT Return air Temperature: 30.0 °C Humidity : 60.0 % Dew Point T.: 21.3 °C</p>	<p>Only visualisation; it indicates the temperature of the ambient return air and it determines the dew point.</p>
<p>A02</p> <p>REGULATION Regulation priority HUMIDITY</p>	<p>Enables to set the unit priority operation mode (humidity set point or temperature set point).</p>

<p>A03</p> <p>SET-POINT LIMITS TEMPERATURE Minimum: 10.0 °C Maximum: 35.0 °C</p>	<p>Enables the limit values for the temperature set point. The temperature required by the end user can not exceed the values set by the manufacturer.</p>
<p>A04</p> <p>SET-POINT LIMITS HUMIDITY Maximum: 30.0 % Maximum: 90.0 %</p>	<p>Enables the limit values for the humidity set point. The humidity required by the end user can not exceed the values set by the manufacturer.</p>
<p>A05</p> <p>TEMPERATURE REGUATION Main differential: 02.0 °C Secondary differential: 03.0 °C</p>	<p>Enables the temperature differential values for the main and the secondary operation mode.</p>
<p>A06</p> <p>HUMIDITY REGUATION Main differential: 05.0 % Secondary differential: 08.0 %</p>	<p>Enables the relative humidity differential values for the main and the secondary operation mode.</p>
<p>A07</p> <p>TEMPERATURE REGUATION OTHER PARAMETERS Dead zone: 01.0 °C</p>	<p>Enables an additional temperature differential value.</p>
<p>A08</p> <p>PUMP MANAGEMENT RECUPERATOR Minimum outdoor temp. for recuperator pump enable: 5.0 °C</p>	<p>Enables the value of the external air temperature under which the heat recovery pump has to be activated. Select ↑ and ↓ and press ENTER to confirm.</p>
<p>A09</p> <p>PUMP MANAGEMENT RECUPERATOR Outdoor air differen. for recuperator pump disable: 2.0 °C</p>	<p>Enables the value of the differential air temperature under which the heat recovery pump has to be de-activated. Select ↑ and ↓ and press ENTER to confirm.</p>
<p>A10</p> <p>PUMP MANAGEMENT RECUPERATOR Minimum discharge air temperature: 08.0 °C</p>	<p>Enables the value of the minimum fresh air temperature at which the unit can operates with compressor On and fresh air damper open. If the discharge air temperature measured by the probe is lower than the set value, the fresh air damper will be closed.</p>
<p>A11</p> <p>PUMP MANAGEMENT RECUPERATOR Fresh air critical temperature: 00.0 °C Regulation reset differential: 02.0 °C</p>	<p>The fresh air critical differential is the temperature of the fresh air at which external air which corresponds to a discharge air temperature under the allowed minimum value (A10). It's a parameter automatically memorized by the control. The differential represents the increase of the fresh air temperature higher that the critical temperature to allow the compressor to work with the standard regulation.</p>
<p>A12</p> <p>PUMP MANAGEMENT RECUPERATOR Time closing dampers and OFF recuperator pump 20 min.</p>	<p>Enables the closing time of the dampers if the unit works in a critical temperature. In this case the unit will work in 100% re-circulation.</p>
<p>A13</p> <p>ANTIFREEZE TRESHOLD MANAGEMENT Fresh air threshold temperature: -05 °C Fresh air threshold differential: 05.0 °C</p>	<p>Enables the minimum fresh air temperature value at which the unit stops the heat recovery and the fresh air operation mode.</p>

<p>A14</p> <p>ANTIFREEZE TRESHOLD MANAGEMENT Discharge threshold temperature: 04.0 °C Discharge threshold differential: 08.0 °C</p>	<p>Enables the value of the minimum discharge air temperature value to allow the unit to work with open dampers without the compressor. If the discharge temperature measured by the probe is lower than the set value, the damper will be closed and the unit will work in re-circulation with the hot water coil.</p>
<p>A15</p> <p>OUT TIME ZONES PARAMETERS Set T: MAIN Set H: MAIN Diff. T: MAIN Diff. H: MAIN Func.: STANDARD+F.A.</p>	<p>This configuration allows to personalize the working modes out of the time zones already set.</p>
<p>A16</p> <p>CONFIG.: COMFORT Set T: MAIN Set H: MAIN Diff. T: MAIN Diff. H: MAIN Func.: STANDARD+F.A.</p>	<p>This operation mode allows the unit to operate at full power with all the enabled resources . This mode of operation is used in periods of average or high occupancy.</p>
<p>A17</p> <p>CONFIG.: ENERGY SAVING Set T: SECONDARY Set H: SECONDARY Diff. T: SECONDARY Diff. H: SECONDARY Func.: STANDARD+F.A.</p>	<p>This operation mode allows the unit to operates with the minimum resources, enabled by operating in ventilation only without integration of compressor nor of external air. This operation mode is used in the stand by periods in which the facility is not active.</p>
<p>A18</p> <p>CONFIG.: NIGHT Set T: SECONDARY Set H: SECONDARY Diff. T: SECONDARY Diff. H: SECONDARY Func.: STANDARD</p>	<p>This operation mode allows the unit to operates with the compressor but without the integration of fresh air. This operation mode is used during non-crowding periods and typically during the night operation.</p>
<p>A19</p> <p>CONFIG.: FREE COOLING Set T: MAIN Set H: MAIN Diff. T: MAIN Diff. H: MAIN Func.: VENTILATION + F.A.</p>	<p>This operation mode allows the unit to operate with fresh air only, without the integration of the compressor. This operation mode is typically used when the outdoor air conditions are able to guarantee acceptable conditions in the room.</p>
<p>A20</p> <p>CONFIG.: OFF Set T: MAIN Set H: MAIN Diff. T: MAIN Diff. H: MAIN Func.: OFF</p>	<p>OFF: Unit in stand-by.</p>
<p>A21</p> <p>MODE FORCING ENERGY SAVING</p>	<p>It used to force a specific operation mode if the circuit terminals are closed.</p>

6.4.1 FREE COOLING operation mode:

This operation mode allows to take advantage of the favorable external air conditions to enhance the efficiency of the system. This operation mode can be activated in three different ways:

1. By time zones
2. By forcing from external contact (see A21 mask)
3. In automatic mode: activated via the settings described in A22 mask. In this case the A23 mask must be set the following parameters:
 Differential enable free cooling: is the minimum difference between the return air temperature and fresh air temperature to be enabled the free cooling mode,
 Bypass differential free cooling: it is the reduction of the enable free cooling differential for it to be disabled the free cooling mode,
 Minimum fresh air temperature value below which the free cooling mode is disabled.
 Fresh air temperature differential: it is the temperature increase above the minimum value so that the free cooling function is enabled.
 In practice, this operation mode is enabled if the fresh air temperature is lower than the return air temperature from the pool and in any case not less than a predetermined minimum value.
 When the free cooling mode is enabled in automatic

When the free cooling mode is enabled in an automatic notification thereof shall be reporting on the main form where the flashing message will appear: "FORCING FREE COOLING"

<p>A22</p> <p>FREECOOLING MANAGEMENT Operating mode change enable through fresh air temperat.: NO</p>	<p>This parameter allows the unit to enable the FC mode function of the fresh air temperature.</p>
<p>A23</p> <p>FREECOOLING MANAGEMENT FC enable : 05.0 °C Enab.Diff.FC : 03.0 °C T.min.fresh.FC : 12.0 °C Diff.f.min.FC : 03.0 °C</p>	<p>These parameters determine the temperature difference between the room air and fresh air to enable and disable the FC mode. They also provide a minimum value of the fresh air temperature below which the FC mode is never enabled.</p>
<p>A24</p> <p>FREECOOLING MANAGEMENT Free cooling mode forcing time 010 min old mod. 010 min</p>	<p>These parameters determine the minimum working period in the FC mode.</p>
<p>A25</p> <p>SUPPLY FAN: Automatic air flow management: Y</p>	<p>This parameter determines if the airflow rate of the supply fan can be managed automatically.</p>
<p>A26</p> <p>SUPPLY FAN: COMFORT Δp: 00080Pa Autom.manag. air flow speed limit value min: 51% max:099%</p>	<p>This parameter determines the differential pressure value in COMFORT mode for the automatic adjustment of the supply airflow.</p>
<p>A27</p> <p>SUPPLY FAN: NRG SAVING Δp: 00060Pa Autom.manag. air flow speed limit value min: 52% max:099%</p>	<p>This parameter determines the differential pressure value in ENERGY SAVING mode for the automatic adjustment of the supply airflow.</p>

<p>A32</p> <p>SUPPLY FAN: COMFORT min:000% max:100%</p> <p>SUPPLY FAN: ENRG SAVING min:000% max:100%</p>	<p>Enables the supply fan speed in the different operation modes.</p> <p>Enables the supply fan speed in the different operation modes.</p>
<p>A34</p> <p>SUPPLY FAN: NIGHT min:000% max:100%</p> <p>SUPPLY FAN: FREE COOL. min:000% max:100%</p>	<p>Enables the supply fan speed in the different operation modes.</p> <p>Enables the supply fan speed in the different operation modes.</p>
<p>A35</p> <p>SUPPLY FAN: N.ZONES min:000% max:100%</p>	<p>Enables the supply fan speed in the different operation modes.</p>
<p>A37</p> <p>EXHAUST F.: COMFORT min:000% max:100%</p> <p>EXHAUST F.: ENRG SAVING min:000% max:100%</p>	<p>Enables the exhaust fan speed in the different operation modes.</p> <p>Enables the exhaust fan speed in the different operation modes.</p>
<p>A38</p> <p>EXHAUST F.: NIGHT min:000% max:100%</p> <p>EXHAUST F.: FREE COOL. min:000% max:000%</p>	<p>Enables the exhaust fan speed in the different operation modes.</p> <p>Enables the exhaust fan speed in the different operation modes.</p>
<p>A40</p> <p>EXHAUST F.: T.ZONES min:000% max:000%</p>	<p>Enables the exhaust fan speed in the different operation modes.</p>
<p>A42</p> <p>FRESH AIR DAMPER Minimum value : 000.0% Maximum value : 100.0%</p>	<p>Enables the fresh air damper minimum and maximum opening values.</p>
<p>A43</p> <p>ALLARM MANAGEMENT Manual reset high press. alarm after N. times x hour:</p>	<p>Enables the maximum number of errors beyond which it is not possible to reset the high pressure alarm.</p>
<p>A44</p> <p>ALLARM MANAGEMENT Delays for low pressure alarm</p>	<p>Shows the maximum time at which the unit operates in unsafe conditions before displays the alarm.</p>
<p>A45</p> <p>ALLARM MANAGEMENT Manual reset low press. alarm after N. times x hour:</p>	<p>Enables the maximum number of errors beyond which it is not possible to reset the low pressure alarm.</p>
<p>A46</p> <p>ALLARM MANAGEMENT Antifreeze alarm delay:</p>	<p>Shows the maximum time at which the unit operates in unsafe conditions before displays the alarm.</p>

<p>A47</p> <p>ALLARM MANAGEMENT High humidity alarm Set-point : 090.0 % Different. : 005.0 % Delay : 010s</p>	<p>Indicates the presence of very high humidity in the room. Does not stop the unit.</p>
<p>A48</p> <p>ALLARM MANAGEMENT Low humidity alarm Set-point : 020.0 % Different. : 005.0 % Delay : 010s</p>	<p>Indicates the presence of very low humidity in the room. Does not stop the unit.</p>
<p>A49</p> <p>ALLARM MANAGEMENT High temperature alarm Set-point : 35.0 °C Different. : 04.0 °C Delay : 010s</p>	<p>Indicates the presence of very high temperature in the room. Does not stop the unit.</p>
<p>A50</p> <p>ALLARM MANAGEMENT Low temperature alarm Set-point : 10.0 °C Different. : 04.0 °C Delay : 010s</p>	<p>Indicates the presence of very low temperature in the room. Does not stop the unit.</p>
<p>A51</p> <p>ALLARM MANAGEMENT Clogged filter alarm delay 060 sec</p>	<p>Shows the maximum time at which the unit operates in unsafe conditions before displays the alarm.</p>
<p>A51a</p> <p>ALLARM MANAGEMENT Fan thermal overload alarm delay Primary fan: 005 sec. Fres air fan: 005 sec.</p>	<p>Shows the supply fan time interval from start up during which the fan thermal protection is ignored.</p>
<p>A52</p> <p>DEFROST MANAGEMENT Set-point : 02.0 °C Differential: 04.0 °C</p>	<p>Enables the temperature set below which the defrost cycle starts.</p>
<p>A53</p> <p>DEFROST MANAGEMENT Delay between two consequent defrost: 030 min</p>	<p>Enables the time interval between 2 consecutive defrost cycles.</p>
<p>A54</p> <p>DEFROST MANAGEMENT Defrost minimum duration: 060 sec. Defrost maximum duration: 012 min Dripping time : 030 sec</p>	<p>Enables the minimum and maximum duration of the defrost cycle.</p>
<p>A55</p> <p>DEFROST MANAGEMENT Manual reset defrost duration alarm after N. times x hour: 3</p>	<p>Shows the maximum time at which the unit operates in unsafe conditions before displays the alarm.</p>

<p>A56</p> <p>COMPRESSOR ENABLING</p> <p>Enable compressor to work?</p> <p style="text-align: right;">Y</p>	<p>Enables the compressor operation.</p>
<p>A57</p> <p>ALARM MANAGEMENT</p> <p>Reset compressor overload alarm?</p> <p style="text-align: right;">NO</p>	<p>Enables the reset of the compressor overload protection. Select with ↑ and ↓ and press ENTER to confirm.</p>
<p>A58</p> <p>HISTORY MANAGEMENT</p> <p>Alarm history delete?</p> <p style="text-align: right;">NO</p>	<p>Enables the alarms history deletion.</p>
<p>A59</p> <p>Enter new maintenance password:</p> <p style="text-align: right;">xxxxx</p>	<p>Enables to change the password level “ Maintenance “.</p>

Press **Esc** key to back to the main menu.

6.5 Alarm history menu

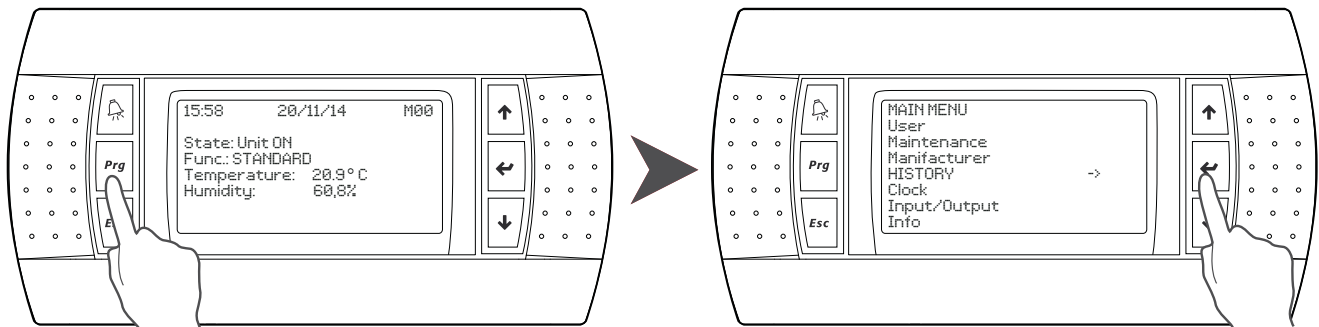

H01 Alarm N°00 Hr. 00:00 of 00/00/00 Th.overl.alarm compressor	It allows the visualisation of all the alarms.
--	--

AL01 Alarm return air humidity probe failure	Visualisation air humidity probe failure.
AL02 Alarm return air temperature probe failure	Visualisation air temperature probe failure.
AL03 Alarm fresh air temperature probe failure	Visualisation fresh air temperature probe failure.
AL04 Alarm disch. air temperature probe failure	Visualisation discharge air temperature probe failure.
AL05 Alarm high pressure from pressure switch	Visualisation high pressure from pressure switch.
AL06 Alarm low pressure from pressure switch	Visualisation low pressure from pressure switch.
AL07 Alarm moisture discharge pump	Visualisation moisture discharge pump (if present).
AL08 Compressor overload alarm	Visualisation compressor overload alarm.
AL17 Antifreeze alarm	Visualisation antifreeze alarm.

Press **Esc** key to back to the main menu.

6.6 Clock Menu

From the main screen press **Prg** to display the available menu:

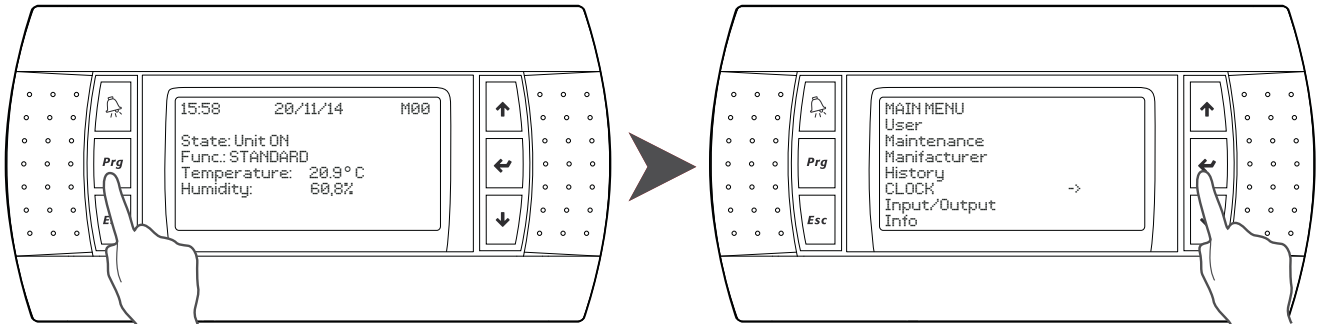

With **↓** and **↑** keys it is possible to navigate inside menu directories. Once chosen the desired one press **←**.

K01	
TIME & DATE SETTINGS Time :16:34 Date :20/11/14 Day :Thursday	Set date and time; Press ENTER to modify, press ENTER to confirm.

Press **Esc** key to back to the main menu.

6.7 Input/Output Menu

From the main screen press **Prg** to display the available menu:

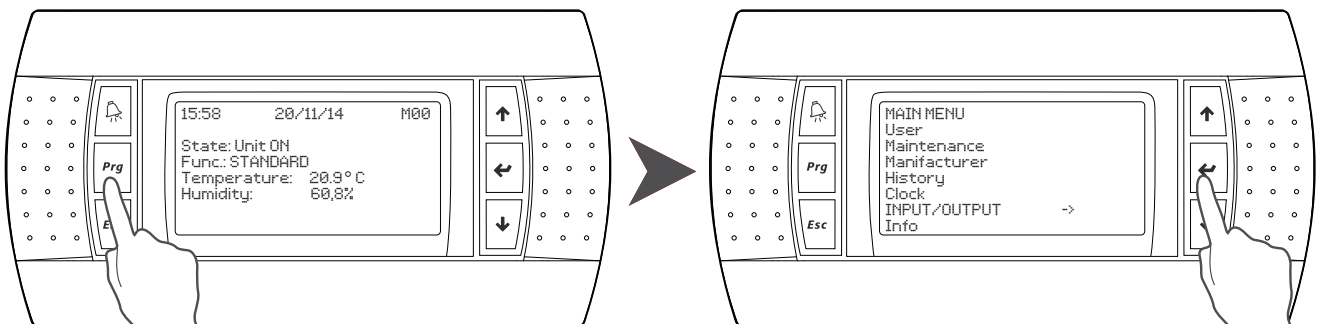

With **↓** and **↑** keys it is possible to navigate inside menu directories. Once chosen the desired one press **←**.

I01	
DIGITAL INPUTS 0=Open, C=Closed ID1 high pressure. : C ID2 low pressure : C ID3 compr. overl. : C ID4 on-off : C ID5 t.ovl.al.p.fan : C ID6 defrost therm. : C	With ↓ and ↑ keys it is possible to navigate inside menu directories. Once chosen the desired one press ← .
I02	
DIGITAL INPUTS 0=Open, C=Closed ID7 op.mode forc. : C ID8 fr.fan.ovld.al : C	With ↓ and ↑ keys it is possible to navigate inside menu directories. Once chosen the desired one press ← .

<p>I03</p> <p>DIGITAL OUTPUTS 0=Open, C=Close N01 compressor : 0 N02 return fan : 0 N03 fan-dampers : 0 N04 desuperheat. : 0 N05 general alarm : 0</p>	<p>With ↓ and ↑ keys it is possible to navigate inside menu directories. Once chosen the desired one press ↵.</p>
<p>I04</p> <p>DIGITAL OUTPUTS 0=Open, C=Close N06 Hot water pump : C N07 recuperat.pump : C N08 Rem.cond.valv. : C</p>	<p>With ↓ and ↑ keys it is possible to navigate inside menu directories. Once chosen the desired one press ↵.</p>
<p>I05</p> <p>ANALOG. INPUTS B1 (Ind.hum.) : 53.8% B2 (Ind. temp.) : 025.8 °C B3 (Defr. temp.) : 002.7 °C B4 (Disc.temp.) : 022.6 °C B5 (Ren. temp.) : 00251 Pa</p>	<p>With ↓ and ↑ keys it is possible to navigate inside menu directories. Once chosen the desired one press ↵.</p>
<p>I06</p> <p>ANALOGIC OUTPUTS Y1 (mod. valv.) : 00.0 V Y2 (main fan) : 05.2 V Y3 (fresh fan) : 00.0 V Y4 (fresh.damp.) : 01.4 V</p>	<p>With ↓ and ↑ keys it is possible to navigate inside menu directories. Once chosen the desired one press ↵.</p>

Press **Esc** key to back to the main menu.

6.8 Info Menu

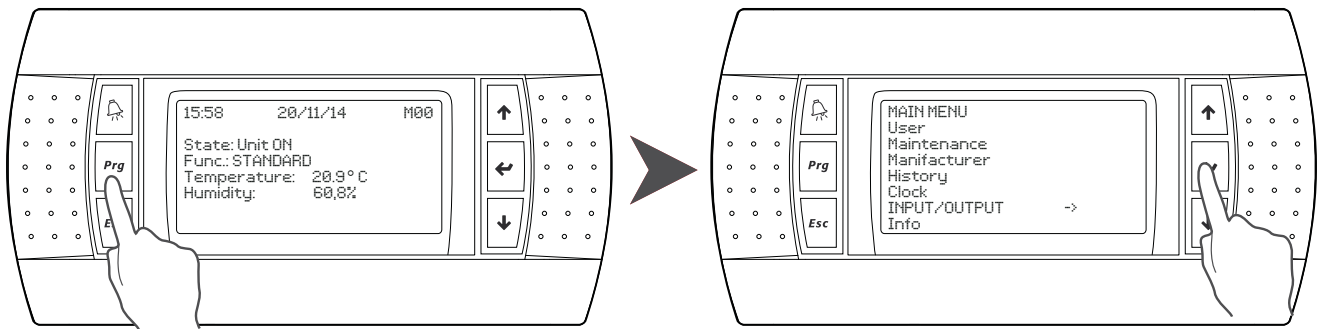

<p>N01 Applicazione DEHUMIDIFIER HIDROS SpA Tel. : +39 049 9731022 Fax. : +39 049 5806928 Mail: info@hidros.it Web: www.hidros.it</p>	<p>It shows the information concerning the Company.</p>
<p>N02 Cod.: SZHIDDE04 Rev.: 00 Date: 14/07/14 BIOS: 04.02 15/11/06 BOOT: 04.03 03/07/06</p>	<p>It shows the information concerning the software .</p>

Press **Esc** key to back to the main menu.

7. MAINTENANCE OF THE UNIT

7.1 General warnings

Maintenance can:

- Keep the equipment operating efficiently
- Prevent failures
- Increase the equipment life



It is advisable to maintain a record book for the unit which details all operations performed on the unit as this will facilitate troubleshooting.



Maintenance must be performed in compliance with all requirements of the previous paragraphs.



Use personal protective equipment required by regulations as compressor casings and discharge pipes are at high temperatures. Coil fins are sharp and present a cutting hazard.

7.2 Drive access

Access to the unit once installed, should only be possible to authorized operators and technicians. The owner of the equipment is the company legal representative, entity or person owns the property where the machine is installed. They are fully responsible for all safety rules given in this manual and regulations.

7.3 Periodical checks



The start-up operations should be performed in compliance with all requirements of the previous paragraphs.



All of the operations described in this chapter **MUST BE PERFORMED BY TRAINED PERSONNEL ONLY**. Before commencing service work on the unit ensure that the electric supply is disconnected. The top case and discharge line of compressor are usually at high temperature. Care must be taken when working in their surroundings. Aluminium coil fins are very sharp and can cause serious wounds. Care must be taken when working in their surroundings. After servicing, replace the cover panels, fixing them with locking screws.

7.3.1 Every 6 months:

It is advisable to perform periodic checks in order to verify the correct working of the unit.

- Check that safety and control devices work correctly as previously described.
- Check all the terminals on the electric board and on the compressor are properly fixed.
- Check and clean the sliding terminals of the contactors.
- Check for water leaks in the hydraulic system.
- Check the filters and if its necessary, replace them.
- Check mounting of fan blades and their balancing.

7.3.2 End of seasons or unit switched off:

If the unit is to be left out of commission for a long period, the hydraulic circuit should be drained down. This operation is compulsory if the ambient temperature is expected to drop below the freezing point of the fluid in the circuit (water or Glycol mix).

7.4 Refrigerant circuit repair



If the refrigerant circuit is to be emptied, all the refrigerant must be recovered using the correct equipment.

For leak detection, the system should be charged with nitrogen using a gas bottle with a pressure reducing valve, until 15 bar pressure is reached. Any leakage is detected using a bubble leak finder. If bubbles appear discharge the nitrogen from the circuit before brazing using the proper alloys.



Never use oxygen instead of nitrogen: explosions may occur.

Site assembled refrigerant circuits must be assembled and maintained carefully, in order to prevent malfunctions.

Therefore:

- Avoid oil replenishment with products that are different from that specified and that are pre-loaded into the compressor.
- In the event of a gas leakage on machines using refrigerant R134A, R410A even if it is only a partial leak, do not top up. The entire charge must be recovered, the leak repaired and a new refrigerant charge weighed in to the circuit.
- When replacing any part of the refrigerant circuit, do not leave it exposed for more than 15 minutes.
- It is important when replacing a compressor that the task be completed within the time specified above after removing the rubber sealing caps.
- When replacing the compressor following a burn out, it is advisable to wash the cooling system with appropriate products including a filter for acid.
- When under vacuum do not switch on the compressor.

8. DECOMMISSIONING

8.1 Disconnect the unit



All decommissioning operations must be performed by authorized personnel in accordance with the national legislation in force in the country where the unit is located.

- Avoid spills or leaks into the environment.
- Before disconnecting the machine please recover:
 - the refrigerant gas;
 - Glycol mixture in the hydraulic circuit;
 - the compressor lubricating oil.

Before decommissioning the machine can be stored outdoors, providing that it has the electrical box, refrigerant circuit and hydraulic circuit intact and closed.

8.2 Disposal, recovery and recycling

The frame and components, if unusable, should be taken apart and sorted by type, especially copper and aluminum that are present in large quantities in the machine.

All materials must be recovered or disposed in accordance with national regulations.

8.3 RAEE Directive (only UE)

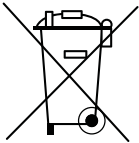

- The RAEE Directive requires that the disposal and recycling of electrical and electronic equipment must be handled through a special collection, in appropriate centers, separate from that used for the disposal of mixed urban waste.
- The user has the obligation not to dispose of the equipment at the end of the useful life as municipal waste, but to send it to a special collection center.
- The units covered by the RAEE Directive are marked with the symbol shown above.
- The potential effects on the environment and human health are detailed in this manual.
- Additional information can be obtained from the manufacturer.

9. DIAGNOSIS AND TROUBLESHOOTING

9.1 Fault finding

All units are checked and tested at the factory before shipment, however, during operation an anomaly or failure can occur.



BE SURE TO RESET AN ALARM ONLY AFTER YOU HAVE REMOVED THE CAUSE OF THE FAULT; REPEATED RESET MAY RESULT IN IRREVOCABLE DAMAGE TO THE UNIT.

Alarm Code	Symptom	Cause alarm	Solving
Unit does not start	Display OFF	Lack of power supply	Connect the unit to power supply; replace main fuses
	Display ON	Unit in humidity set	Set a lower set point
	Display OFF	Power phase reversed	Reverse 2 power phases
AL05 Allarme alta pressione	Insufficient airflow	Dirty air filters	Clean air filters
	Insufficient airflow	Open panels, obstructed suction side, not enough fan static pressure	Close the panels, remove eventual obstruction from the ducts, increase fan static pressure
	Insufficient airflow	Broken fan belt	Replace fan belt
AL06 Low pressure alarm	Low refrigerant charge	Possible refrigerant leakages	Repair and re-charge
AL07 Alarm condensate discharge pump	High condensate water level	Defect discharge pump	Replace discharge pump
AL08 Compressor thermal protection	Too high input current	Compressor defect	Replace compressor

10. DIMENSIONAL DRAWINGS

Dimensional drawing UTA 015 - 020

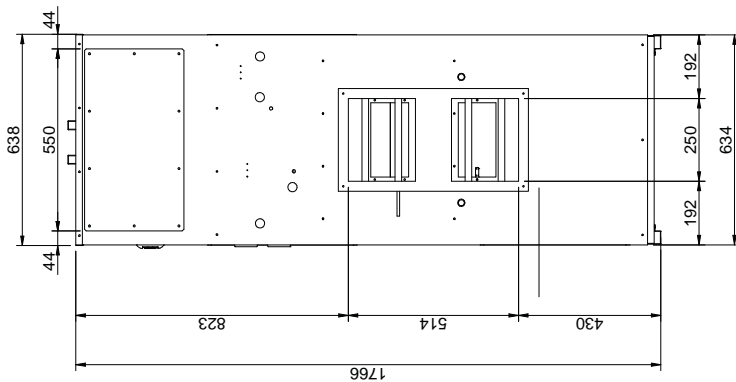
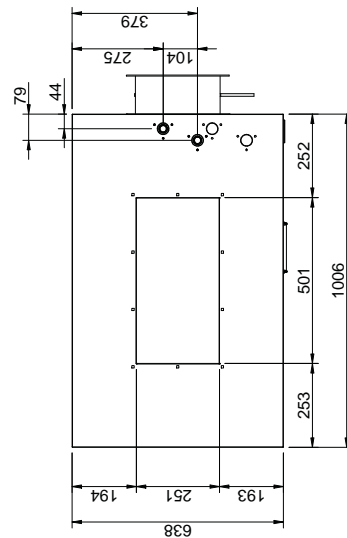
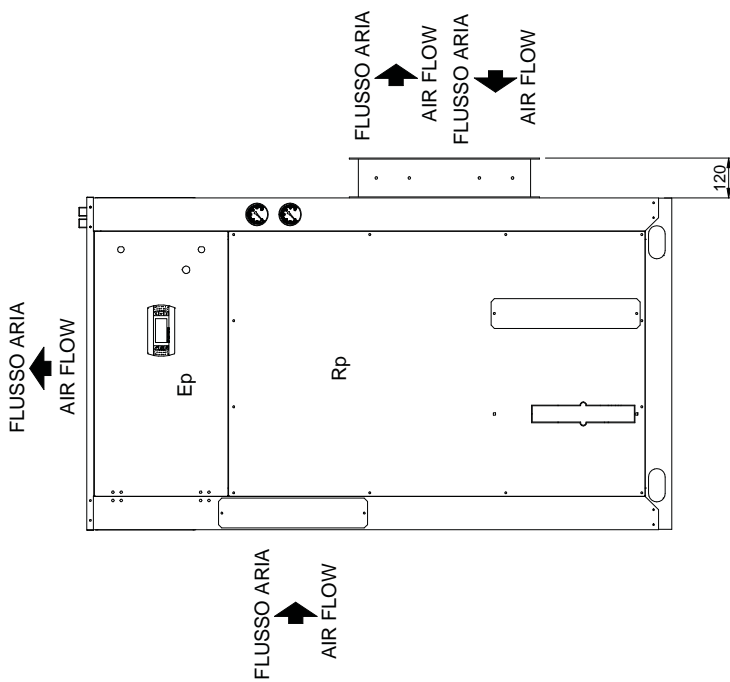
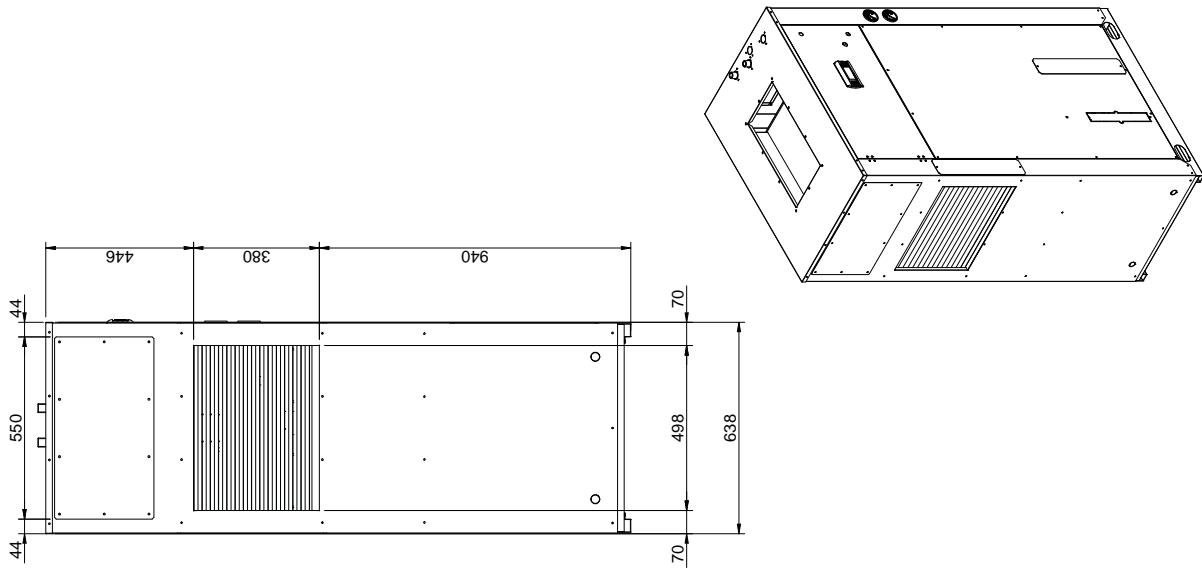

Rp	REMOVABLE PANEL
Ep	ELECTRICAL PANEL
Es	INPUT POWER
Cd	DRAIN
IN 1 Ø 3/4" G M	WATER INLET
OUT 1 Ø 3/4" G M	WATER OUTLET

Dimensional drawing UTA 015 - 020 (with DBRC)

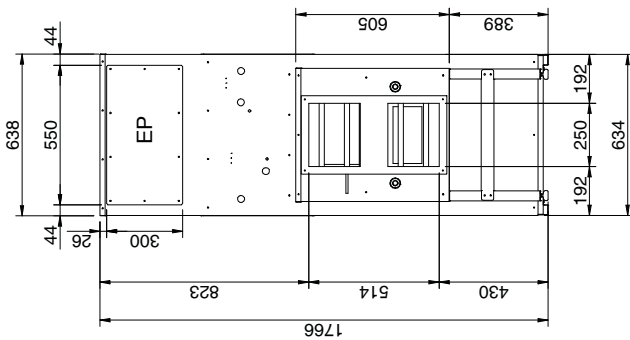
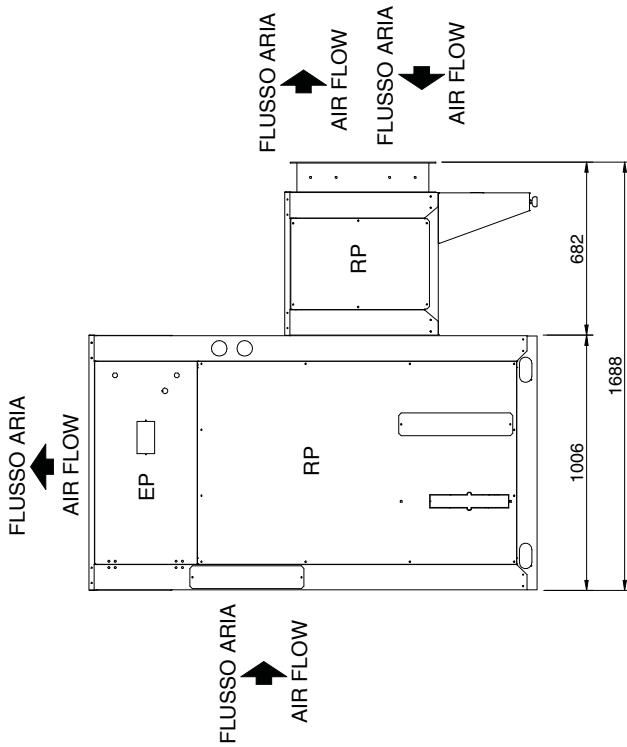
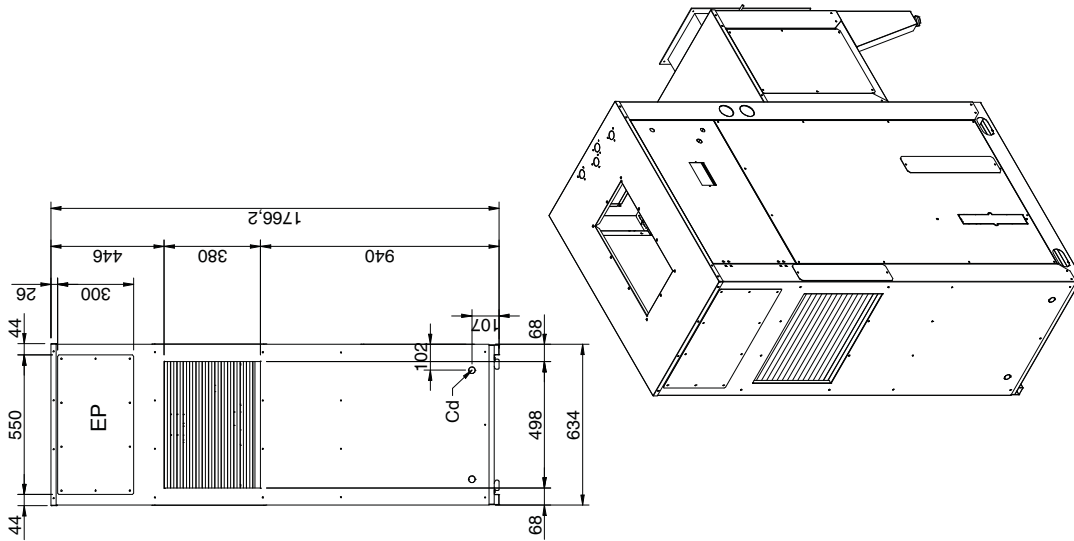

Rp	REMOVABLE PANEL
Ep	ELECTRICAL PANEL
Es	INPUT POWER
Cd	DRAIN
IN Ø 3/4" G M	WATER INLET
OUT Ø 3/4" G M	WATER OUTLET

Dimensional drawing UTA and UTA with DBRC 028 - 035

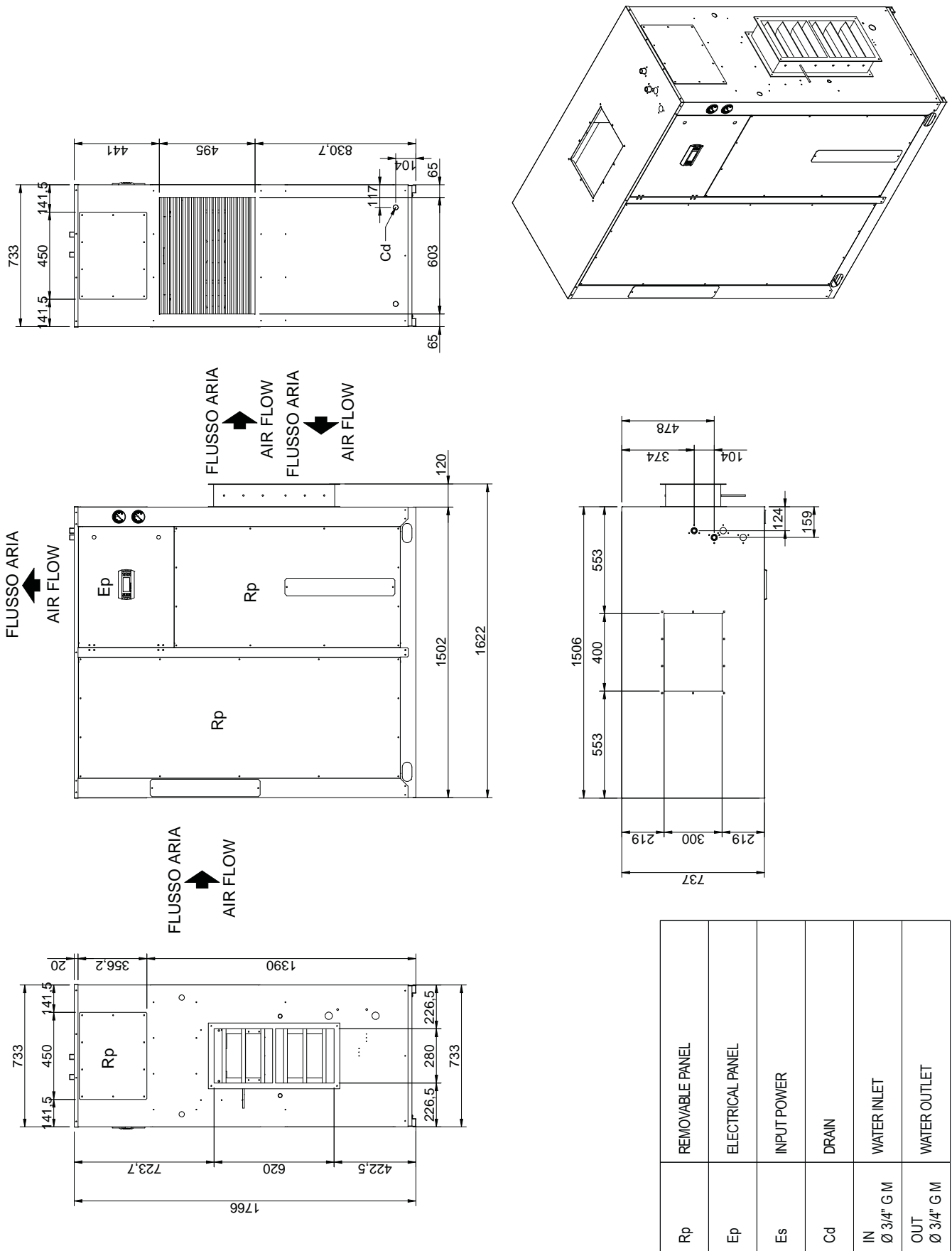

Dimensional drawing UTA and UTA with DBRC 042 - 052 - 060

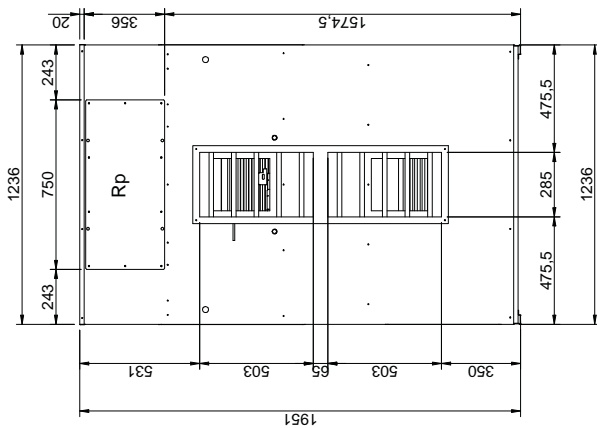
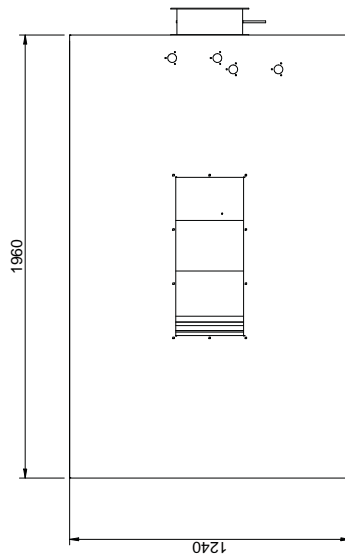
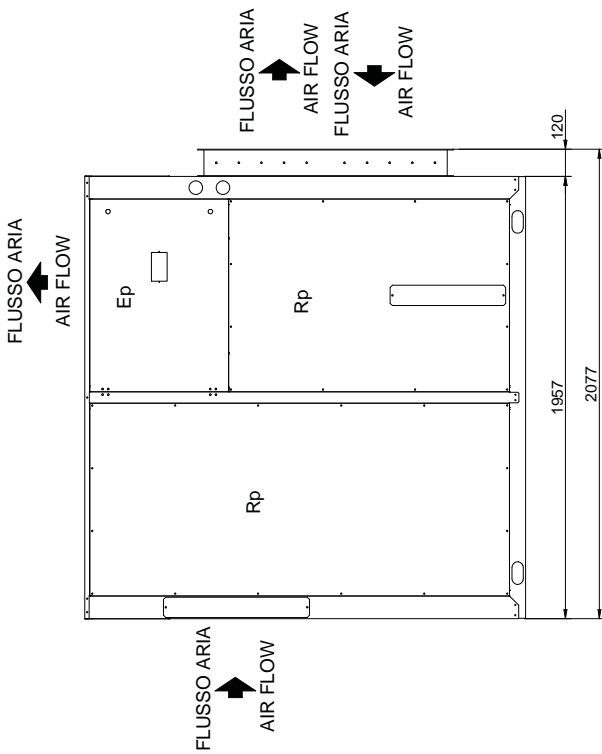
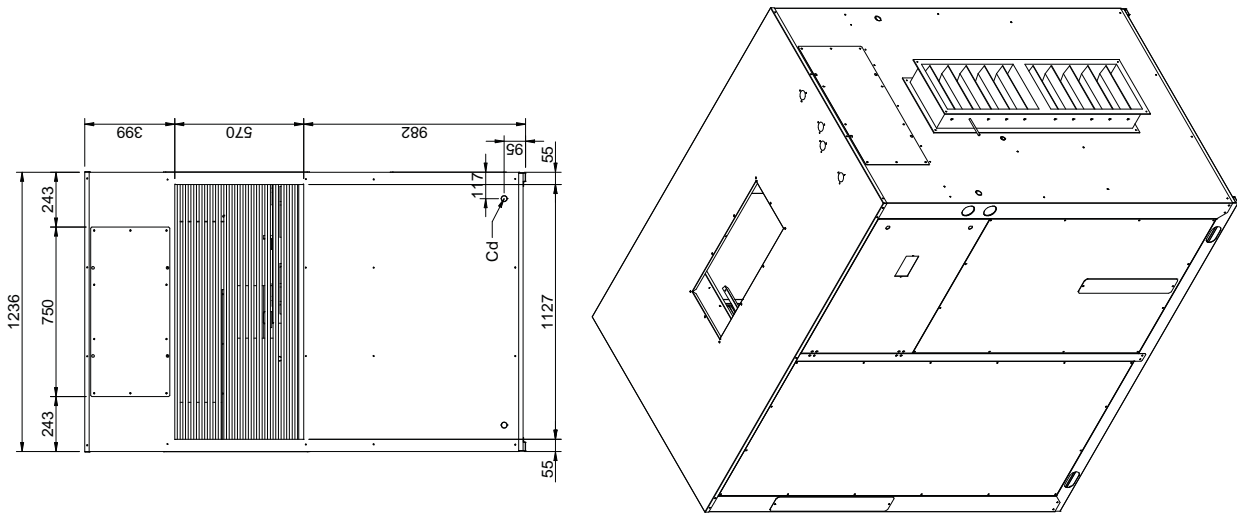

Rp	REMOVABLE PANEL
Ep	ELECTRICAL PANEL
Es	INPUT POWER
Cd	DRAIN
IN Ø 3/4" G M	WATER INLET
OUT Ø 3/4" G M	WATER OUTLET

Dimensional drawing external unit UTAZ 15 - 20

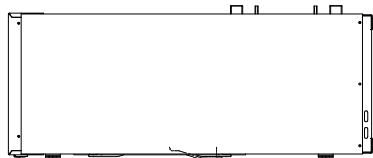
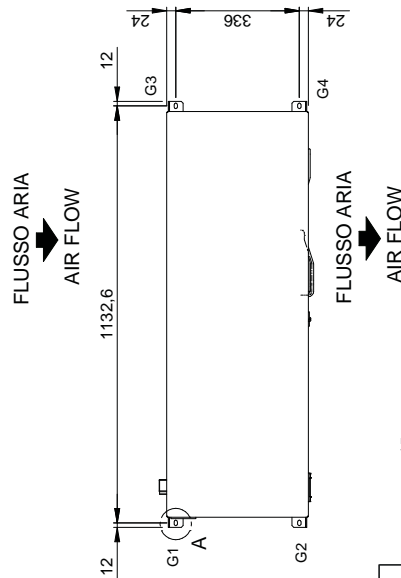
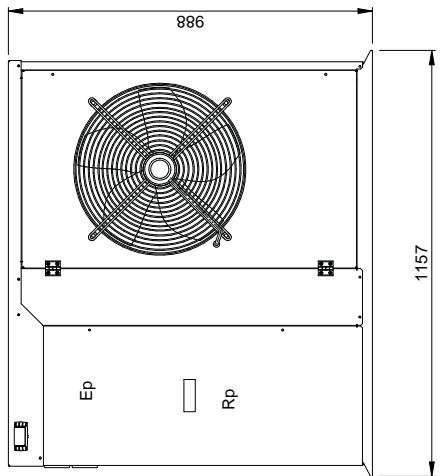
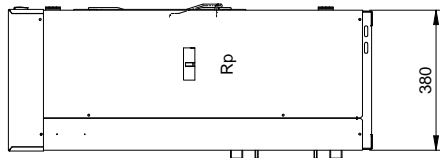
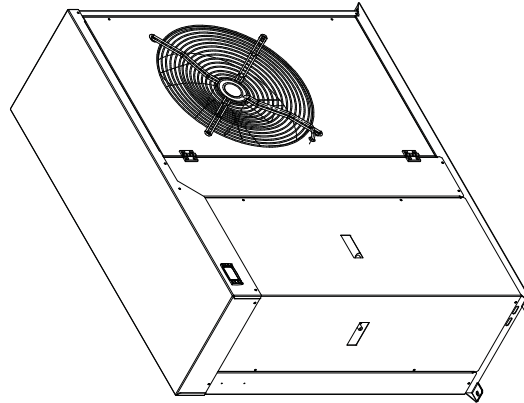
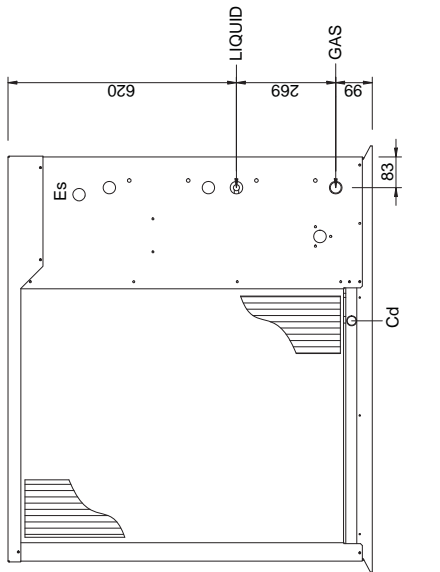

Rp	REMOVABLE PANEL
Ep	ELECTRICAL PANEL
Es	INPUT POWER
Cd	DRAIN
GAS Ø 22	MOTOEVAPORATING INLET
LIQUID Ø 12	MOTOEVAPORATING OUTLET

Dimensional drawing external unit UTAZ 28 - 35 - 42

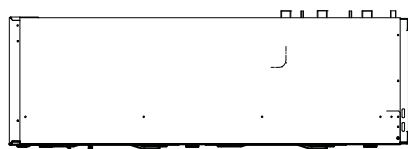
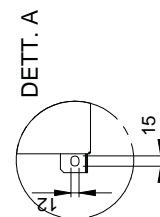
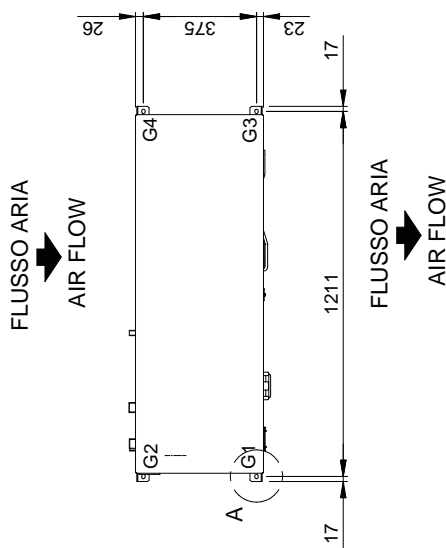
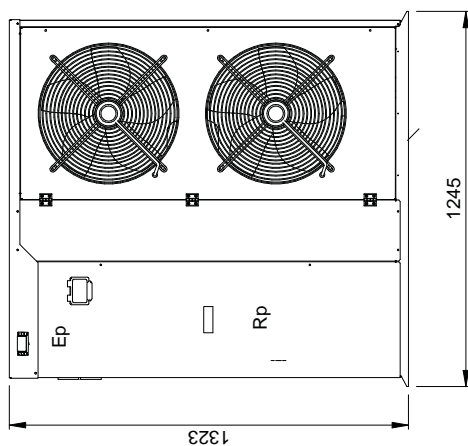
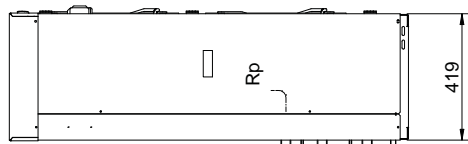
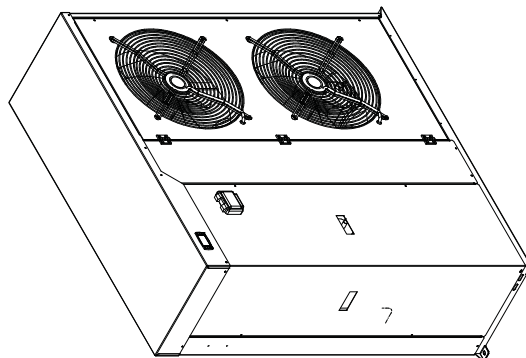
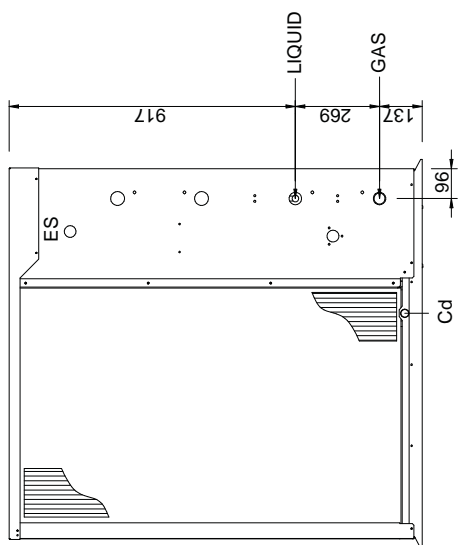

Rp	REMOVABLE PANEL
Ep	ELECTRICAL PANEL
Es	INPUT POWER
Cd	DRAIN
GAS Ø 28	MOTEOVAPORATING INLET
LIQUID Ø 16	MOTEOVAPORATING OUTLET

Dimensional drawing external unit UTAZ 52 - 60

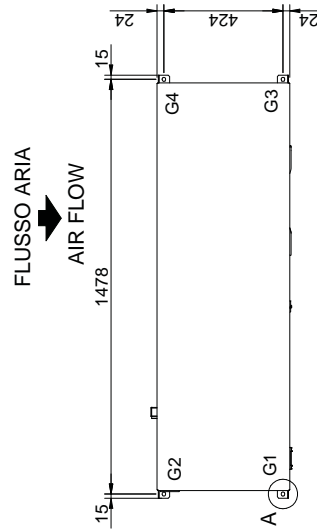
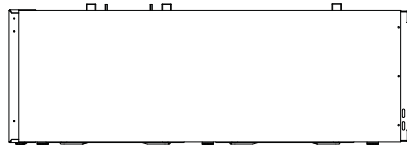
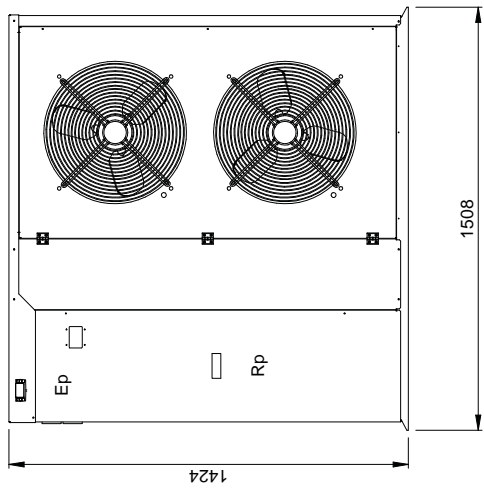
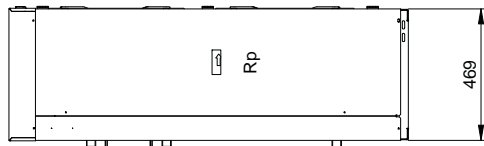
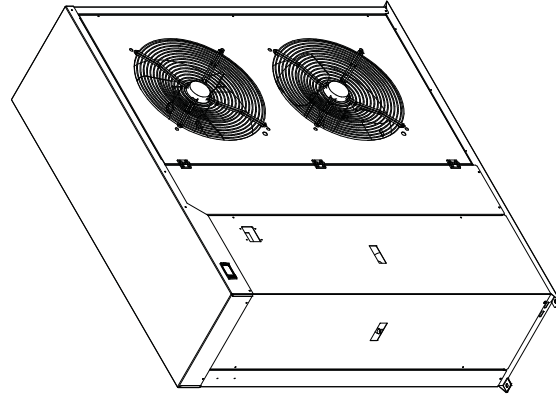
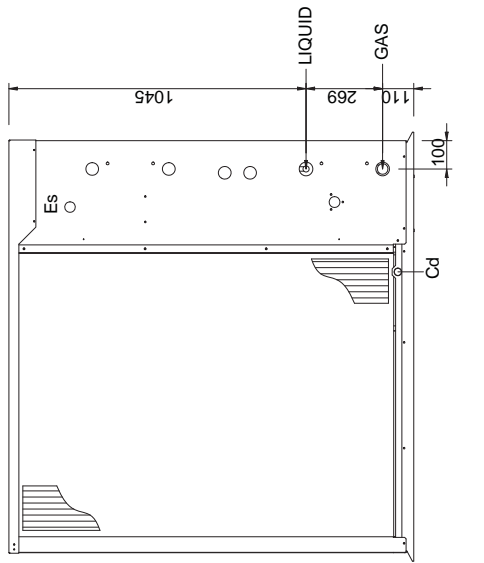

FLUSSO ARIA
AIR FLOW

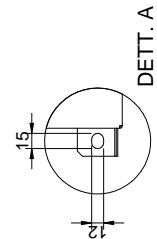

DETT. A

Rp	REMOVABLE PANEL
Ep	ELECTRICAL PANEL
Es	INPUT POWER
Cd	DRAIN
GAS Ø 28	MOTIEVAPORATING INLET
LIQUID Ø 16	MOTIEVAPORATING OUTLET



HIDROS Spa

Sede legale: Via della Croce Rossa; 32/2 ▪ Cap 35129 Padova Italy
Sede operativa: Via E. Mattei, 20 ▪ cap 35028 ▪ Piove di Sacco (Pd) Italy
Tel. +39 049 9731022 ▪ Fax +39 049 5806928
Info@hidros.it ▪ www.hidros.it

P.IVA e C.F 03598340283 ▪ R.E.A. PD-322111

REG. IMP. PD 0359834 028 3 ▪ VAT NUMBER: IT 03598340283 ▪ CAPITALE SOCIALE € 1.200.000,00 i.v.

Technical data shown in this booklet are not binding.

HIDROS S.p.A. shall have the right to introduce at any time whatever modifications necessary to the improvement of the product.
